

CarboVis 705 IQ TS Co

OPTICAL SENSOR FOR CARBON SUM PARAMETER, SOLIDS CONTENT (TS) AND
COLORATION



a xylem brand

Copyright

© 2021 Xylem Analytics Germany GmbH
Printed in Germany.

Contents

1	Overview	5
1.1	How to use this component operating manual	5
1.2	Field of application	6
1.3	Measuring principle of the sensor CarboVis 705 IQ TS Co	6
1.4	Structure of the sensor CarboVis 705 IQ TS Co	7
2	Safety	8
2.1	Safety information	8
2.1.1	Safety information in the operating manual	8
2.1.2	Safety signs on the product	8
2.1.3	Further documents providing safety information	8
2.2	Safe operation	9
2.2.1	Authorized use	9
2.2.2	Requirements for safe operation	9
2.2.3	Unauthorized use	9
3	Commissioning	10
3.1	IQ SENSOR NET system requirements	10
3.2	Scope of delivery of the CarboVis 705 IQ TS Co	10
3.3	Installation	11
3.3.1	Mounting the sensor	11
3.3.2	Mounting the shock protectors	13
3.3.3	Connecting the sensor to the IQ SENSOR NET	14
3.4	Initial commissioning	16
3.4.1	General information	16
3.4.2	Sensor structure	17
3.4.3	Settings for CarboVis 705 IQ (main sensor)	18
3.4.4	Settings for CarboVis 705 IQ (virtual sensor)	21
3.4.5	Settings for SolidVis 705 IQ	22
3.4.6	Settings for ColorVis 705 IQ	22
4	Measurement / Operation	25
4.1	Determination of measured values	25
4.2	Measuring operation	26
4.3	Calibration	26
4.3.1	Overview	26
4.3.2	User calibration	29
4.3.3	Sensor check/ <i>Zero adjustment</i>	33

5	Maintenance and cleaning	39
5.1	Maintenance	39
5.2	Sensor cleaning	39
5.2.1	Cleaning agents and accessories	39
5.2.2	General steps to be taken	40
5.2.3	Basic cleaning	41
5.2.4	Cleaning the measuring gap	42
6	Spare parts, maintenance equipment, accessories	43
7	What to do if...	45
8	Technical data	48
8.1	Measurement characteristics	48
8.2	Application characteristics	49
8.3	General data	50
8.4	Electrical data	52
9	Indexes	53
9.1	Explanation of the messages	53
9.1.1	Error messages	54
9.1.2	Informative messages	56
9.2	Status info	57
10	Appendix: Glossary	58

1 Overview

1.1 How to use this component operating manual

Structure of the IQ SENSOR NET operating manual

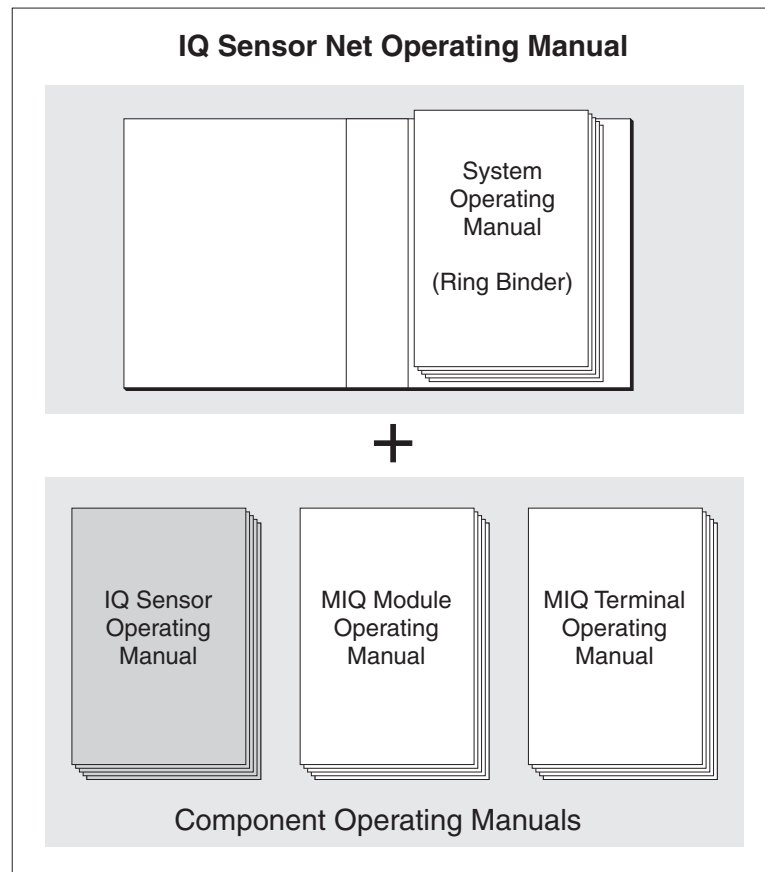

figure 1-1 Structure of the IQ SENSOR NET operating manual

The IQ SENSOR NET operating manual has a modular structure like the IQ SENSOR NET itself. It consists of a system operating manual and the operating manuals of all the components used.

Please file this component operating manual into the ring binder of the system operating manual.

1.2 Field of application

The CarboVis 705 IQ TS Co is an online sensor for the on-site determination of carbon sum parameters, solids content and coloration in waste water treatment plants.

Range of application Control, regulation, monitoring

Measuring location Outlet

Ultrasound cleaning system The ultrasound cleaning system ensures low maintenance and long-term reliable measurement operation. The ultrasound source integrated in the sensor excites the measurement windows to produce vibrations in the ultrasound range. The movement of the surface as a result of this prevents the growth of pollution in almost all cases and, thus, ensures reliable measured values during continuous operation.

Compressed air cleaning (option) The sensor is designed to be equipped with an additional compressed air-driven cleaning system, which supports the ultrasound cleaning system as necessary.

1.3 Measuring principle of the sensor CarboVis 705 IQ TS Co

The sensor operates according to the measuring principle of spectrometry.

Any substance contained in a measuring solution attenuates a light beam that penetrates the measuring solution. The attenuation (absorbance) of the light beam is measured for individual wavelengths.

The extent of the absorbance depends on the amount of the substance.

With this measuring principle, measuring does not take place continuously but at intervals.

1.4 Structure of the sensor CarboVis 705 IQ TS Co

The sensor has a light source (1), a measuring gap (3) to enable the contact of light with the measuring solution, and a detector (5) to measure the attenuated light beam.

The sender of the optical system (2) directs a light beam, the measuring beam (6), through the measuring solution and a second light beam, the reference beam (8), over a distance without measuring solution. The test sample is between both measurement windows (3) in the measuring gap.

The receiver of the optical system (4) directs the measuring beam and reference beam to the detector. In the detector, the light is received by fixed photo diodes.

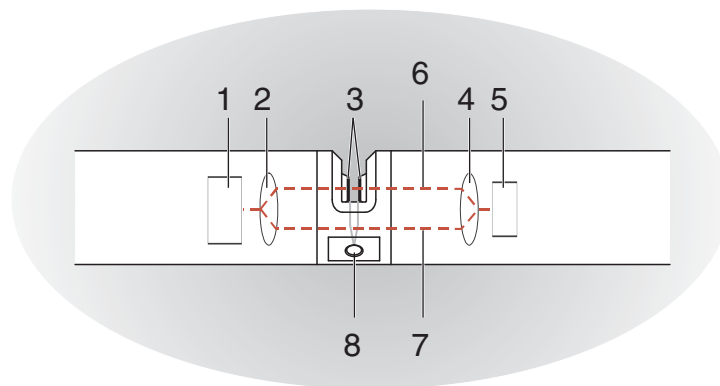

figure 1-2 Structure of the sensor

1	Light source
2	Sender of the optical system
3	Measuring gap between the measurement windows
4	Receiver of the optical system
5	Detector
6	Measuring beam
7	Reference beam
8	Connection for the optional compressed air cleaning system

2 Safety

2.1 Safety information

2.1.1 Safety information in the operating manual

This operating manual provides important information on the safe operation of the product. Read this operating manual thoroughly and make yourself familiar with the product before putting it into operation or working with it. The operating manual must be kept in the vicinity of the meter so you can always find the information you need.

Important safety instructions are highlighted in this operating manual. They are indicated by the warning symbol (triangle) in the left column. The signal word (e.g. "CAUTION") indicates the danger level:



WARNING

indicates a possibly dangerous situation that can lead to serious (irreversible) injury or death if the safety instruction is not followed.



CAUTION

indicates a possibly dangerous situation that can lead to slight (reversible) injury if the safety instruction is not followed.

NOTE

indicates a situation where goods might be damaged if the actions mentioned are not taken.

2.1.2 Safety signs on the product

Note all labels, information signs and safety symbols on the product. A warning symbol (triangle) without text refers to safety information in this operating manual.

2.1.3 Further documents providing safety information

The following documents provide additional information, which you should observe for your safety when working with the measuring system:

- Operating manuals of other components of the IQ SENSOR NET system (power packs, controller, accessories)
- Safety datasheets of calibration and maintenance equipment (e.g. cleaning solutions).

2.2 Safe operation

2.2.1 Authorized use

The authorized use of the CarboVis 705 IQ TS Co is its use as a sensor in the IQ SENSOR NET. Only the operation and running of the product according to the instructions and technical specifications given in this operating manual is authorized (see chapter 8 TECHNICAL DATA). Any other use is considered unauthorized.

2.2.2 Requirements for safe operation

Note the following points for safe operation:

- The product may only be operated according to the authorized use specified above.
- The product may only be supplied with power by the energy sources mentioned in this operating manual.
- The product may only be operated under the environmental conditions mentioned in this operating manual.
- The product may not be opened.

2.2.3 Unauthorized use

The product must not be put into operation if:

- it is visibly damaged (e.g. after being transported)
- it was stored under adverse conditions for a lengthy period of time (storing conditions, see chapter 8 TECHNICAL DATA).

3 Commissioning

3.1 IQ SENSOR NET system requirements

Software statuses of the controller and terminal components

The operation of the CarboVis 705 IQ TS Co requires the following software versions in the IQ SENSOR NET:

- DIQ/S 282/284 Controller software: Version 3.81 or higher
- DIQ/S 182 Controller software: Version 3.45 or higher
- MIQ/MC3 Controller software: Version 3.81 or higher
- MIQ/MC2 Controller software: Version 3.81 or higher
- MIQ TC 2020 3G/XT Controller software: Version 3.81 or higher

For cleaning with compressed air via a relay

- DIQ/S 282/284 Controller software: Version 3.81 or higher
- DIQ/S 182 Software version: Version 3.45 or higher
- MIQ/CR3 Software version: Version 2.90 or higher
- MIQ/R6 Software version: Version 2.90 or higher
- MIQ/CHV PLUS Software version: Version 2.90 or higher

3.2 Scope of delivery of the CarboVis 705 IQ TS Co

The following parts are included in the scope of delivery:

- SensorCarboVis 705 IQ TS Co
- Sensor sleeve
- Shock protectors
- Operating manual

3.3 Installation

3.3.1 Mounting the sensor

NOTE

The sensor is an optical precision instrument that should be protected against shocks. Make sure that the distances to the wall, bottom and other installation surroundings are sufficient. If necessary, protect the end of the sensor against hitting with the protective ring provided. Mount any fixing elements only on the sturdy metal shaft.

NOTE

Always make sure the surface of the enclosure is not damaged by sharp-edged objects. The enclosure of the sensor may not touch any metallic objects in order to prevent contact corrosion.

NOTE

Do not suspend the sensor on the sensor connection cable. Risk of cable break and water penetration at the cable gland.

A wide range of mounting accessories is available for the installation of the CarboVis 705 IQ TS Co (see chapter 6 SPARE PARTS, MAINTENANCE EQUIPMENT, ACCESSORIES). Thus, all prevalent ways of mounting are possible.

Generally, observe the following general rules when mounting the sensor at the measuring location:

Horizontal installation

When mounting the sensor horizontally, the measuring gap opening should be on the side. Thus, any air bubbles can escape upward after cleaning and no sediment can collect in the measuring gap. The sensor should be aligned in parallel with the flow direction.

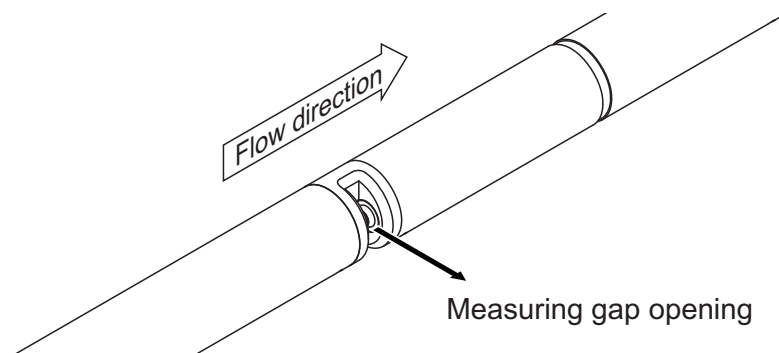

figure 3-1 Horizontal installation

Vertical installation For vertical installation, mount the sensor in a position that allows interfering elements in the measuring gap to escape with the current. In the case of vertical installation, the minimum flow rate is 0.2 m/s so the measuring gap is kept clean optimally.

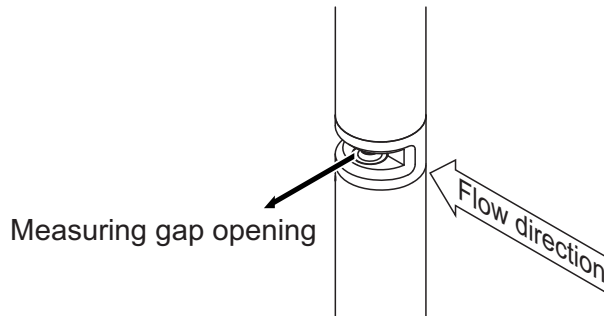

figure 3-2 Vertical installation

Protection against shocks When installing the sensor, always make sure it cannot knock against a wall or another obstacle. Make sure the safety margins are sufficient (e. g. with suspended mounting). Mount the enclosed shock protectors (see section 3.3.2). Their soft rubber compound absorbs hard impacts.

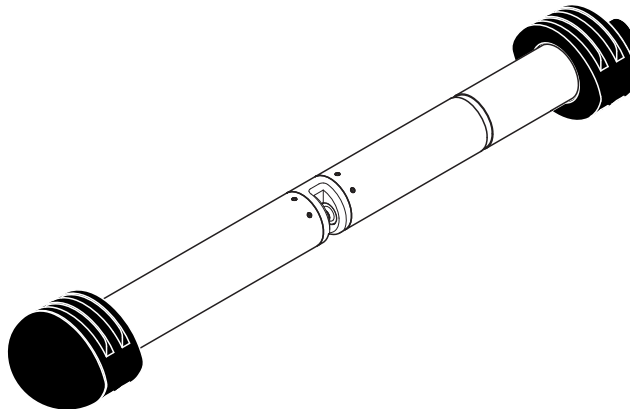

figure 3-3 Sensor with mounted shock protectors

3.3.2 Mounting the shock protectors

The shock protectors consist of two rings, a cap and four cable ties. To mount the shock protectors, proceed as follows:

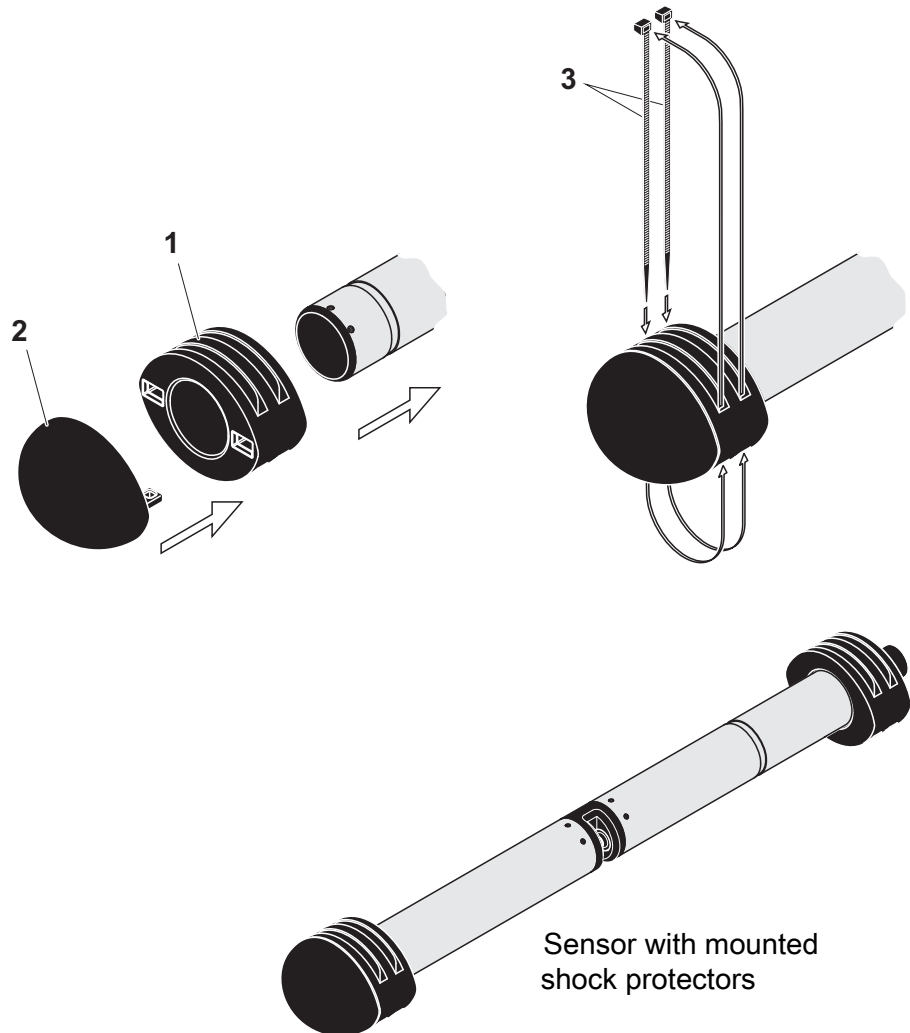

figure 3-4 Mounting the shock protectors

1. Plug the cap (pos. 2 in figure 3-4) on one of the two rings (pos. 1).
2. Put the assembled unit on the sensor end and fix it with 2 cable ties (pos. 3) as shown in figure 3-4.
3. Put the second ring on the cable end of the sensor and fix it with the remaining two cable ties in the same way.

3.3.3 Connecting the sensor to the IQ SENSOR NET

Connection cable A sensor connection cable of the SACIQ or SACIQ SW type is required to connect the sensor. The cable is available in different lengths. Compared to the standard model SACIQ, the SACIQ SW sensor connection cable is optimized regarding its corrosion resistance in seawater and brackish water and adapted for use in conjunction with the CarboVis 705 IQ TS Co. Information on this and other IQ SENSOR NET accessories is given in the WTW catalog and on the Internet.



How to connect the SACIQ (SW) sensor connection cable to the terminal strip of an MIQ module is described in chapter 3 INSTALLATION of the IQ SENSOR NET system operating manual.

Are the plug connections dry? Before connecting the sensor and sensor connection cable, please make sure the plug connections are dry. If moisture gets into the plug connections, first dry the plug connections (dab them dry or blow them dry using compressed air).

NOTE

Do not suspend the sensor on the sensor connection cable but use the suitable mounting equipment. Information on this and other IQ SENSOR NET accessories is given in the WTW catalog and on the Internet.

Connecting the sensor to the sensor connection cable

1. Take the protective caps off the plug connections of the sensor and the SACIQ (SW) sensor connection cable and keep them safe.
2. Plug the socket of the SACIQ (SW) sensor connection cable onto the plug head connector of the sensor. At the same time, rotate the socket so that the pin in the plug head connector (1) clicks into one of the two holes in the socket.
3. Then screw the coupling ring (2) of the sensor connection cable onto the sensor up to the stop.

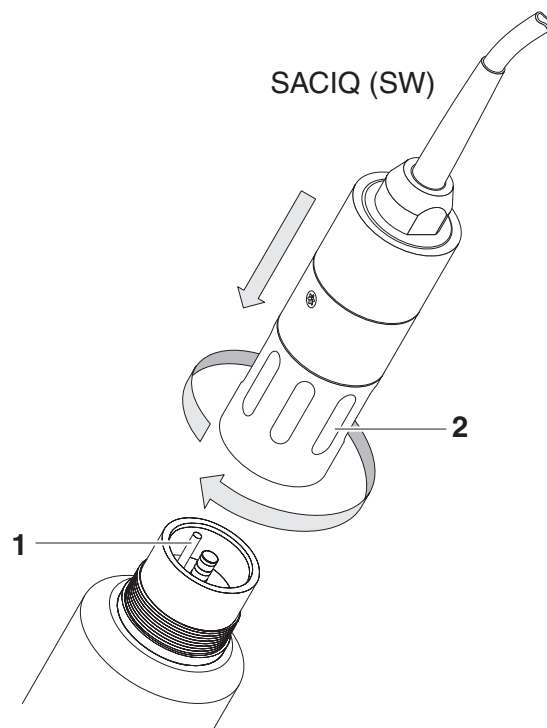

figure 3-5 Connecting the sensor

3.4 Initial commissioning

3.4.1 General information

**CAUTION**

Never look into the measuring window or put objects into the measuring window during operation! The emitted UV radiation can damage the eyes!

In the case of authorized use, inadvertent eye contact with the light beam is not possible.

Measuring location

The sensor is prepared for operation in the outlet of the waste water treatment plant and calibrated in the factory. The sensor is immediately ready to measure.



How to adjust the settings is described in the following section (section 3.4.3).

User calibration after initial commissioning

On the basis of a reference measurement ("laboratory value"), check whether the default settings deliver sufficiently accurate measured values or whether you want to carry out a user calibration (see section 4.3 CALIBRATION).

3.4.2 Sensor structure

The physical sensor is the sensor with the instrument or model designation CarboVis 705 IQ TS Co. The physical sensor processes the measurement signal (absorbance spectrum) and supplies up to 5 measurement results to the IQ SENSOR NET. The measurement results are administrated like 5 sensors that differ in hierarchy as follows:

Main sensor The sensor for carbon measurement is the main sensor. The main sensor is always displayed. It registers on the system under the designation CarboVis 705 IQ and the series number of the physical sensor.

Secondary sensor The sensor for measuring the solids content is a secondary sensor. The secondary sensor is always displayed (some settings, such as *Measuring location*, are only possible for the main sensor). It registers on the system under the designation SolidVis 705 IQ and the series number of the physical sensor.

The sensor for coloration measurement is a secondary sensor. The secondary sensor is always displayed (some settings, such as *Measuring location*, are only possible for the main sensor). It registers on the system under the designation ColorVis 705 IQ and the series number of the physical sensor.

Virtual sensor Any other sensor is a virtual sensor. The virtual sensor can be displayed optionally (some settings, such as *Measuring location* and the number of sensors, are only possible when the main sensor is displayed). It logs on to the system with the series number of the physical sensor.

Sensor overlapping settings and functions Some settings and functions are sensor overlapping. Sensor overlapping settings are generally edited in the setting menu of the main sensor. These are the most important sensor overlapping settings and functions:

- Times of the measuring cycle
(*Meas. interval, Cleaning duration Air, Adjustment phase* etc.)
- *Signal smoothing*

3.4.3 Settings for CarboVis 705 IQ (main sensor)

Measuring cycle A measuring cycle consists of the cleaning procedure, the adjustment time for the measuring system and the determination of the measured value. The following graphic demonstrates the relevant settings:

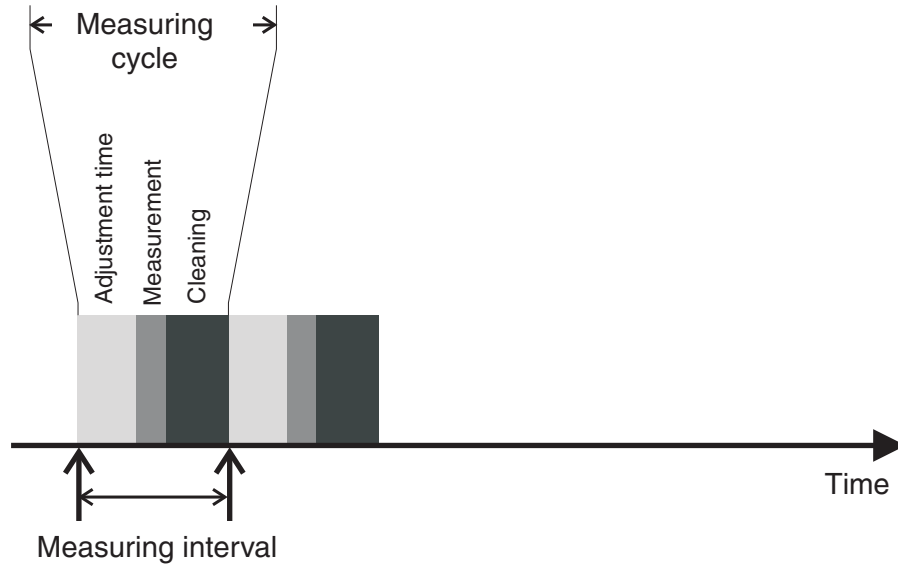

figure 3-6 Measuring cycle of the sensor

Carrying out settings Using <S>, switch from the measured value display to the main menu of the settings. Then navigate to the setting menu (setting table) of the sensor. The procedure is described in detail in your IQ SENSOR NET system operating manual.



A change of the following settings will take some time (up to a few minutes) until it can be seen in the measured value display:

- *Measuring mode*
- *Number of C-sensors*
- *Num. of Color-sensors*

Default values are marked in **bold**.

Menu item	Settings	Explanations
<i>Measuring mode</i>	<ul style="list-style-type: none"> ● <i>COD spectr., total</i> ● <i>COD spectr., dissolv</i> ● <i>TOC spectr., correl.</i> ● <i>BOD spectr., correl.</i> ● <i>DOC spectr., correl.</i> ● <i>SAC 254, total</i> ● <i>SAC 254, dissolved</i> ● <i>UVT 254, total</i> ● <i>UVT 254, dissolved</i> 	<p>The measured parameter is displayed in the selected citation form.</p> <p>When changing the <i>Measuring mode</i> setting, always check the <i>Measuring location</i> setting.</p> <p>If the previously set measurement location is not available for the selected measuring mode, the measurement location is automatically changed.</p>
<i>Measuring location</i>	<i>Outlet</i> (permanently set)	Measurement location or application of the sensor.
<i>Measuring range</i>	-	Display of the measuring range (see chapter 8 TECHNICAL DATA).
<i>Cal - # raw value 1</i>	Value pairs of the user calibration (see section 4.3.2). Note: Leave those values unchanged during the initial commissioning.	
<i>Cal - ref. value 1</i>		
<i>Cal - # raw value 2</i>		
<i>Cal - ref. value 2</i>		
<i>Number of C-sensors</i>	1 ... 2	Adjustable number of sensors for the measurement of carbon. The settings for additional sensors are done in the menus for the respective sensors.
<i>Num. of Color-sensors</i>	1 ... 2	Adjustable number of sensors for the measurement of the coloration. The settings for the additional sensor are done in the menu for the sensor.
<i>Zero adjustment</i>	<i>Factory</i> <i>User</i>	Setting of which zero adjustment is used in the sensor. <ul style="list-style-type: none"> ● Factory zero adjustment or ● Zero adjustment carried out last
<i>Signal smoothing</i>	<ul style="list-style-type: none"> ● <i>On</i> ● <i>Off</i> 	Switching on/off the signal smoothing. For details, see <i>Response time t90</i> .

Menu item	Settings	Explanations
<i>Response time t90</i>	3 ... 60 min	<p>Response time of the signal smoothing. Depending on the sample matrix, measured values can vary more or less strongly (e.g. due to foreign bodies or air bubbles). The signal filter (here, the <i>Response time t90</i>) reduces the limits of variation of the measured values.</p> <p>The <i>Response time t90</i> specifies the time after which 90 % of a signal change are displayed.</p> <p>This menu item is only available with: <i>Signal smoothing = On</i></p> <p>The specified time is used as a guide value for low (10 min) to high (60 min) signal smoothing and can deviate from the value that was set.</p>
<i>Cleaning mode</i>	<ul style="list-style-type: none"> ● On ● Off 	Switching on/off the automatic, time-controlled cleaning function.
<i>Cleaning type</i>	<ul style="list-style-type: none"> ● Ultrasound ● Air ● Ultrasound+air 	<p>Cleaning methods / adjustment time</p> <p>This menu item is only available with: <i>Cleaning mode = On</i></p> <p>The duration of the air cleaning is set in the menu item <i>Cleaning duration Air</i>.</p>
<i>Cleaning duration Air</i>	0.5 ... 10 ... 300 s	<p>This menu item is only available with: <i>Cleaning type = Air</i> and <i>Cleaning type = Ultrasound+air</i></p> <p>For this setting to be effective, the setting <i>150 - Settings of outputs and links / Relay function / Sensor-controlled / Pulse length / Automatic</i> has to be selected for the linked relay.</p> <p>Note the software requirements for components with the relay outputs MIQ/CR3, MIQ/R6, MIQ/CHVPlus, DIQ/S 182, DIQ/S 28X (see section 3.1).</p>
<i>Save and quit</i>	-	The system confirms the saving of the settings and the display switches to the next higher level.
<i>Quit</i>	-	The display switches to the next higher level without saving the new settings.

3.4.4 Settings for CarboVis 705 IQ (virtual sensor)

Carrying out settings Using <S>, switch from the measured value display to the main menu of the settings. Then navigate to the setting menu (setting table) of the sensor. The procedure is described in detail in your IQ SENSOR NET system operating manual.

Default values are marked in **bold**.

Menu item	Settings	Explanations
<i>Measuring mode</i>	<ul style="list-style-type: none"> ● <i>COD spectr., total</i> ● <i>COD spectr., dissolv</i> ● <i>TOC spectr., correl.</i> ● <i>BOD spectr., correl.</i> ● <i>DOC spectr., correl.</i> ● <i>SAC 254, total</i> ● <i>SAC 254, dissolved</i> ● <i>UVT 254, total</i> ● <i>UVT 254, dissolved</i> 	The measured parameter is displayed in the selected citation form.
<i>Measuring location</i>	<i>Outlet</i> (permanently set)	<p>Measurement location or application of the sensor.</p> <p>The setting is done in the setting menu of the relevant main sensor.</p>
<i>Measuring range</i>	-	Display of the measuring range (see chapter 8 TECHNICAL DATA).
<i>Cal - # raw value 1</i>	Value pairs of the user calibration (see section 4.3.2). Note: Leave those values unchanged during the initial commissioning.	
<i>Cal - ref. value 1</i>		
<i>Cal - # raw value 2</i>		
<i>Cal - ref. value 2</i>		
<i>Main sensor</i>		Information that there are further sensor overlapping settings in the setting menu of the relevant main sensor (<i>Meas. interval, Cleaning duration Air, Signal smoothing</i> etc.).
<i>Save and quit</i>	-	The system confirms the saving of the settings and the display switches to the next higher level.
<i>Quit</i>	-	The display switches to the next higher level without saving the new settings.

3.4.5 Settings for SolidVis 705 IQ

Carrying out settings Using <S>, switch from the measured value display to the main menu of the settings. Then navigate to the setting menu (setting table) of the sensor. The procedure is described in detail in your IQ SENSOR NET system operating manual.

Default values are marked in **bold**.

Menu item	Settings	Explanations
<i>Measuring mode</i>	<i>TSS</i>	Display of the measuring mode (TSS = total suspended solids measurement)
<i>Measuring range</i>	-	Display of the measuring range (see chapter 8 TECHNICAL DATA).
<i>Cal - # raw value 1</i>	Value pairs of the user calibration for TSS measurement (see section 4.3.2). <u>Note:</u> Leave those values unchanged during the initial commissioning.	
<i>Cal - ref. value 1</i>		
<i>Cal - # raw value 2</i>		
<i>Cal - ref. value 2</i>		
<i>Main sensor</i>		Information that there are further sensor overlapping settings in the setting menu of the relevant main sensor (<i>Meas. interval, Cleaning duration Air, Signal smoothing</i> etc.).
<i>Save and quit</i>	-	The system confirms the saving of the settings and the display switches to the next higher level.
<i>Quit</i>	-	The display switches to the next higher level without saving the new settings.

3.4.6 Settings for ColorVis 705 IQ

Carrying out settings Using <S>, switch from the measured value display to the main menu of the settings. Then navigate to the setting menu (setting table) of the sensor. The procedure is described in detail in your IQ SENSOR NET system operating manual.

Default values are marked in **bold**.

Menu item	Settings	Explanations
<i>Measuring mode</i>	<ul style="list-style-type: none"> ● <i>Hazen 340</i> ● <i>Hazen 350</i> ● <i>Hazen 390</i> ● <i>Hazen 445</i> ● <i>Hazen 455</i> ● <i>Hazen 465</i> ● <i>ISO 410</i> 	<p>The measured parameter is displayed in the selected citation form.</p> <ul style="list-style-type: none"> ● Hazen: Measurement based on DIN EN ISO 6271-2:2015, at specified wavelength ● ISO: Measurement based on DIN EN ISO 7887:2012-04 Method C, at 410 nm
<i>Measuring range</i>	-	Display of the measuring range (see chapter 8 TECHNICAL DATA).
<i>Color</i>	<i>True (TC)</i> <i>Apparent (AC)</i>	<ul style="list-style-type: none"> ● TC (True Color): with turbidity compensation For the <i>True (TC)</i> setting, a <i>Factor turbidity</i> can be set (see below). ● AC (Apparent Color): without turbidity compensation
<i>Factor turbidity</i>	<i>0.1 ... 1.0 ... 2.0</i>	<p>This menu item is only available with: Setting <i>Color: True (TC)</i>.</p> <p>The turbidity of a test sample is part of the sample matrix and affects the measured value of online measurements. The effect of the turbidity on the measured value is eliminated in the laboratory by measuring a filtrated sample. The effect of the turbidity measured in the lab can be entered in the sensor as the <i>Factor turbidity</i> to achieve a permanent turbidity compensation.</p>
<i>Cal - # raw value 1</i>	Value pairs of the user calibration for TSS measurement (see section 4.3.2). Note: Leave those values unchanged during the initial commissioning.	
<i>Cal - ref. value 1</i>		
<i>Cal - # raw value 2</i>		
<i>Cal - ref. value 2</i>		
<i>Main sensor</i>		Information that there are further sensor overlapping settings in the setting menu of the relevant main sensor (<i>Meas. interval, Cleaning duration Air, Signal smoothing</i> etc.).

Menu item	Settings	Explanations
<i>Save and quit</i>	-	The system confirms the saving of the settings and the display switches to the next higher level.
<i>Quit</i>	-	The display switches to the next higher level without saving the new settings.

4 Measurement / Operation

4.1 Determination of measured values

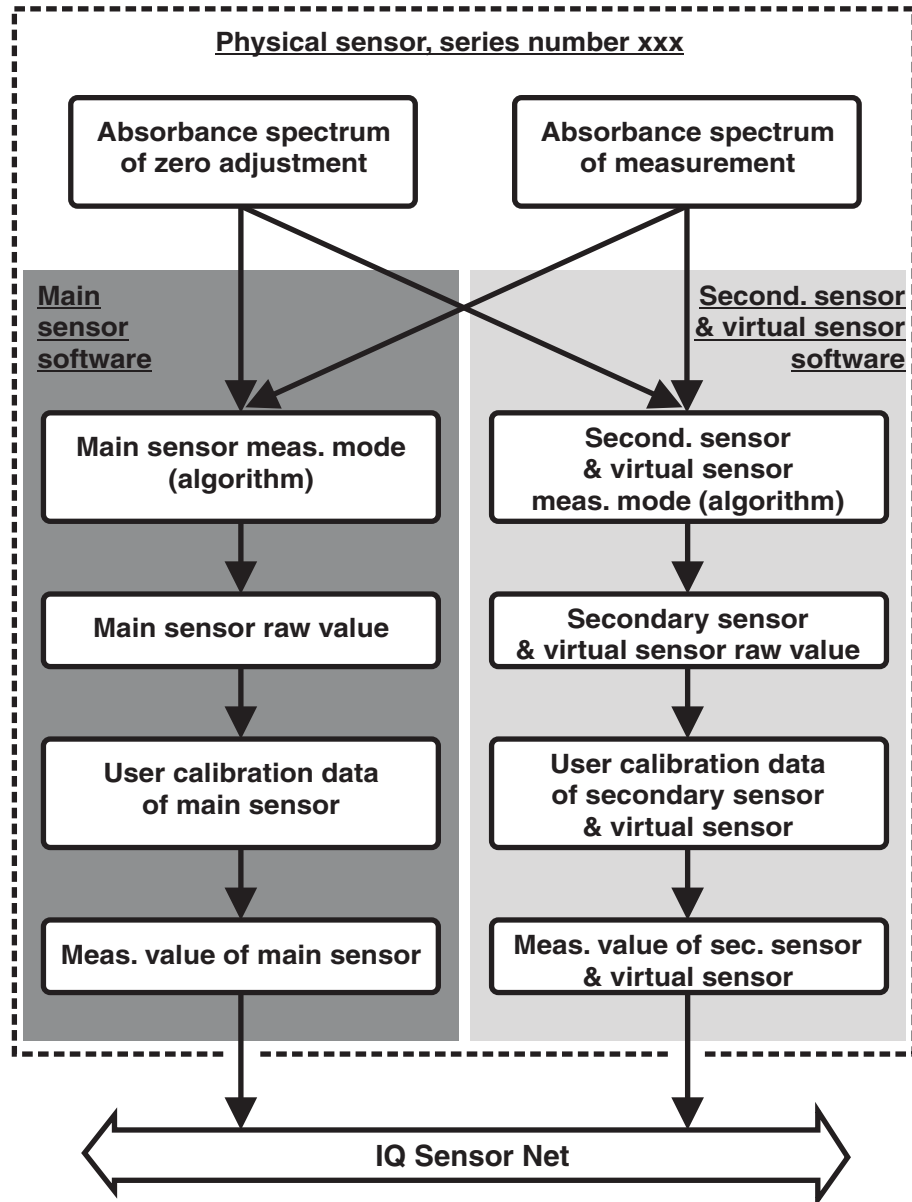



figure 4-1 Determination of measured values

During a measurement, the absorbance spectrum of the test sample is recorded and set against the stored absorbance spectrum of a zero adjustment (measurement in ultrapure water). The algorithm for the calculation depends on the selected application and/or the measuring location. The resulting raw value can be adjusted to an independent reference measurement with the aid of a so-called user calibration.

4.2 Measuring operation



CAUTION
 Never look into the measuring window or put objects into the measuring window during operation! The emitted UV radiation can damage the eyes!
 In the case of authorized use, inadvertent eye contact with the light beam is not possible.

Measured value display

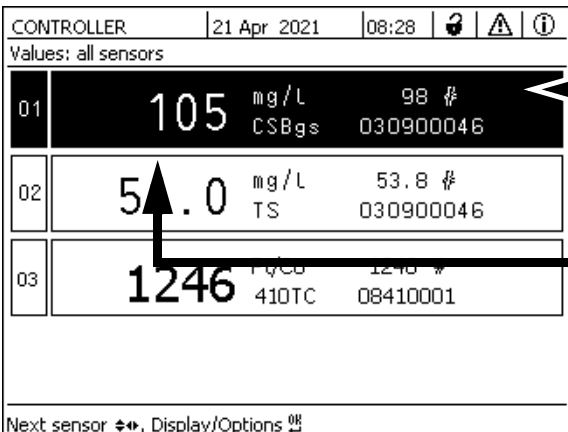

CONTROLLER		21 Apr 2021	08:28	🔒	⚠️	ℹ️
Values: all sensors						
01	105	mg/L	98	#	Raw value, identifiable by #	
		CSBgs	030900046			
02	5.0	mg/L	53.8	#	Measured value	
		TS	030900046			
03	1246	mg/L	1246	#		
		TQCO	08410001			
Next sensor ⬅️➡️, Display/Options 🗄️						

figure 4-2 CarboVis 705 IQ TS Co in the measured value display

Factors affecting the measured values

The following factors can adversely affect the measurement quality:

- The measuring gap is not sufficiently filled and flowed through by the test sample
- Foreign bodies and air bubbles are in the measuring gap
- Extraordinary changes (interferences) of the sample matrix
- Contaminated measurement windows due to difficult sample matrix
- Damaged measuring windows
- Lacking quality of the zero adjustment, e. g. due to contaminated ultrapure water
- The user calibration is not representative (or erroneous)

4.3 Calibration

4.3.1 Overview

In the delivery condition, the sensor is precalibrated and ready to measure (see section 3.4.1).

There are two types of calibration that are included into the calculation of the

measured value at different points (see section 4.1):

- User calibration (see section 4.3.2)
- Sensor check/*Zero adjustment* (see section 4.3.3).

An overview diagram of the calibration procedures can be found on page 34.

User calibration With a user calibration you compensate for the influence of the test sample. The user calibration requires a successful *Sensor check (H₂O dest.)* and a valid *Zero adjustment*.

We recommend to check the current user calibration against independent comparison measurements if you suspect a basic change of the characteristics of the test sample. If the comparison measurements show clear deviations, these can be compensated by a user calibration.

Recalibrating after changing the measuring location



Each time after the application or measurement location was changed, we recommend to carry out a *Zero adjustment* (and, if the *Sensor check (H₂O dest.)* was not successful, also a *Zero adjustment* with user calibration if necessary).



The data of the user calibration are stored in the IQ SENSOR NET controller and thus assigned to the measuring location (not to the sensor). The calibration data of the *Zero adjustment* are stored in the sensor.

Sensor check (H₂O dest.)

The characteristics of a sensor and thus the measured values provided by it change in the course of time.

The reasons for this can be the aging of the sensor, or contamination or mechanical damage of the sensor. Contamination or mechanical damage in the area of the measuring chamber or on the measurement windows affect the measured values.



In spectroscopy, even very small contamination that is not visible to the eye can considerably affect the measured value. The proper and thorough cleaning of the sensor is the basis for reliable measurement data.

A *Sensor check (H₂O dest.)* determines the condition of the sensor. By checking the sensor with the aid of the *Sensor check (H₂O dest.)* you can rapidly see any changes of the sensor and whether it needs to be cleaned or if any other actions have to be taken.

A *Sensor check (H₂O dest.)* should be carried out twice per year at regular intervals. An extraordinary *Sensor check (H₂O dest.)* should be carried out if you suspect that the sensor has been damaged such as by mechanical shock, or if the measured values do not seem plausible.

Zero adjustment

While the *Sensor check (H₂O dest.)* just determines the current state of the sensor, a *Zero adjustment* can be used to compensate for changes of the

sensor. A zero adjustment can be required if, for example, the *Sensor check (H₂O dest.)* is not successful even after the sensor was thoroughly cleaned.



The sensor should always be very thoroughly cleaned prior to a zero adjustment.

If the *Zero adjustment* is not successful, the sensor is blocked for measurement. A successful *Zero adjustment* is required for the determination of measured values.

***Sensor check
(standard)***

Use the *Sensor check (standard)* to check the sensor with a standard solution (see chapter 6 SPARE PARTS, MAINTENANCE EQUIPMENT, ACCESSORIES). During the check, the recorded spectrum is compared to a reference spectrum of the standard solution stored in the sensor.

4.3.2 User calibration

Calibration points and value pairs

The adjustment is carried out at one or two points within the measuring range. A value pair is determined at each point. Each value pair consists of the raw value of the CarboVis 705 IQ TS Co sensor and the corresponding reference value.

Each value pair has to be determined at the same time and place as the test sample as possible. At the time of the calibration, the test sample should be in a condition that is typical of the application.

Selection of calibration points

If the required accuracy is low, the default setting of the first value pair can be adopted unchanged. The first value pair is equivalent to the zero point in this case. The second value pair should be close to the working point of the application. This method results in a single-point calibration.

If the application has to cover a wide value range with high measuring accuracy, both value pairs should be used for calibration. When doing so, the calibration value pairs should be determined and input at the limits of the application range as possible.

You obtain samples of different concentrations e. g. by taking two samples during clearly different conditions of the plant (dry period and rain period).



The measurement results will be ever more accurate the closer the composition of the test sample corresponds to the status at the time of the calibration. If there is a fundamental change of the characteristics of the sample, a new calibration may be necessary.

Storage location of user calibration data

The calibration data of the user calibration are stored in the IQ SENSOR NET controller. They are loaded into the sensor during operation and automatically assigned to the replacement sensor if the sensor is exchanged.

Performing a user calibration

Proceed as follows if you want to perform a user calibration:

1. Bring the sensor into the measuring position.
2. Switch to the measured value display with **<M>**.
3. Use **<▲▼◀▶>** to select the CarboVis 705 IQ TS Co sensor.
4. Call up calibration with **<C>**. The *Wartungszustand: Verknüpfte Ausgänge werden eingefroren.* window appears.



By activating the maintenance condition, linked outputs remain in their present state. The cleaning and the determination of measured values are switched off. The measured value display shows a flashing, invalid measured value ("----").

5. Confirm the maintenance condition with **<OK>**.
6. Select the menu item *Single measurement*. The measurement is started. After the measurement, read the raw value (without dimension) and note it down. In the case of fluctuating values, carry out several single measurements and average the individual raw values.
7. Take a sample at the same time as the measurement and as close to the sensor as possible.
8. Determine the reference value and note it down as a value pair together with the raw value.
9. For a two-point calibration:
Determine the second value pair (step 6 to step 8).



At least one value pair and a maximum of two value pairs can be entered for a valid calibration. The values must be in ascending order. If they are not in ascending order, a calibration error will occur.

10. CarboVis 705 IQ TS Co Switch off the maintenance condition (use **<▲▼◀▶>** to select the sensor, press **<OK>** and make the setting in the *Anzeige/Optionen* menu).
11. Switch to the measured value display with **<M>**. The measured value stops flashing.
12. Sort the values pairs in ascending order.
13. In the *Einstellungen Sensoren/Differenzsensoren* menu, enter the value pair or pairs (see the following table).



The entry of calibration values outside the measuring range leads to a calibration error.

Default values are marked in bold.

Menu item	Settings	Explanations
<i>Cal - # raw value 1</i>	<u>CarboVis, ColorVis:</u> -10000.00 ... 0.00 ... 20000.00 <u>SolidVis:</u> -10000.00 ... 0.00 ... 5000.00	Raw value of the first value pair (lower concentration). For single-point calibration, enter 0.
<i>Cal - ref. value 1</i>	<u>CarboVis, ColorVis:</u> 0.00 ... 20000.00 <u>SolidVis:</u> 0.00 ... 5000.00	Reference value of the first value pair (lower concentration). For single-point calibration, enter 0.
<i>Cal - # raw value 2</i>	<u>CarboVis, ColorVis:</u> -10000.00 ... 0.00 ... 20000.00 <u>SolidVis:</u> -10000.00 ... 0.00 ... 5000.00	Raw value of the second value pair (higher concentration) or raw value of the single-point calibration.
<i>Cal - ref. value 2</i>	<u>CarboVis, ColorVis:</u> 0.00 ... 20000.00 <u>SolidVis:</u> 0.00 ... 5000.00	Reference value of the second value pair (higher concentration) or reference value of the single-point calibration.

Calibration evaluation The entered calibration data are checked for plausibility by the system. The check can have the following results:

Display	Meaning/actions
Measured value display	Successful new valid calibration value pairs were entered for the sensor.
"----"	Calibration value pairs not accepted. Sensor is blocked for measurement. A log book message is generated. Causes: <ul style="list-style-type: none"> ● Ascending order not observed. ● At least one value is outside the measuring range.



Information on the contents and structure of the log book and how you can call it up is given in the LOG BOOK chapter of the IQ SENSOR NET system operating manual.

The user calibration is not recorded in the calibration history. You can, however, view the current value pairs in the *Einstellungen Sensoren/Differenzsensoren* menu at any time.

4.3.3 Sensor check/*Zero adjustment*

NOTE

The sensor check or Zero adjustment must be carried out under absolutely clean conditions. If you do not work carefully enough the Zero adjustment can deteriorate the measuring quality.

Ultrapure water (H₂O dist.)	As ultrapure water exclusively use distilled or deionized water that is suitable for analysis purposes.
Storage location of the <i>Zero adjustment</i>	The data of the sensor checks are not stored. The data of the user zero adjustment are stored in the sensor.
Outlet	A successful <i>Sensor check (H₂O dest.)</i> is the prerequisite for a valid user calibration. After each <i>Sensor check (H₂O dest.)</i> the sensor is evaluated. A changed sensor evaluation proves that the cleaning was effective.

The steps of the sensor check or *Zero adjustment* are identical except for the used check solutions (ultrapure water or standard solution) and are described together below. The sensor check and *Zero adjustment* are carried out with the aid of the sensor sleeve.

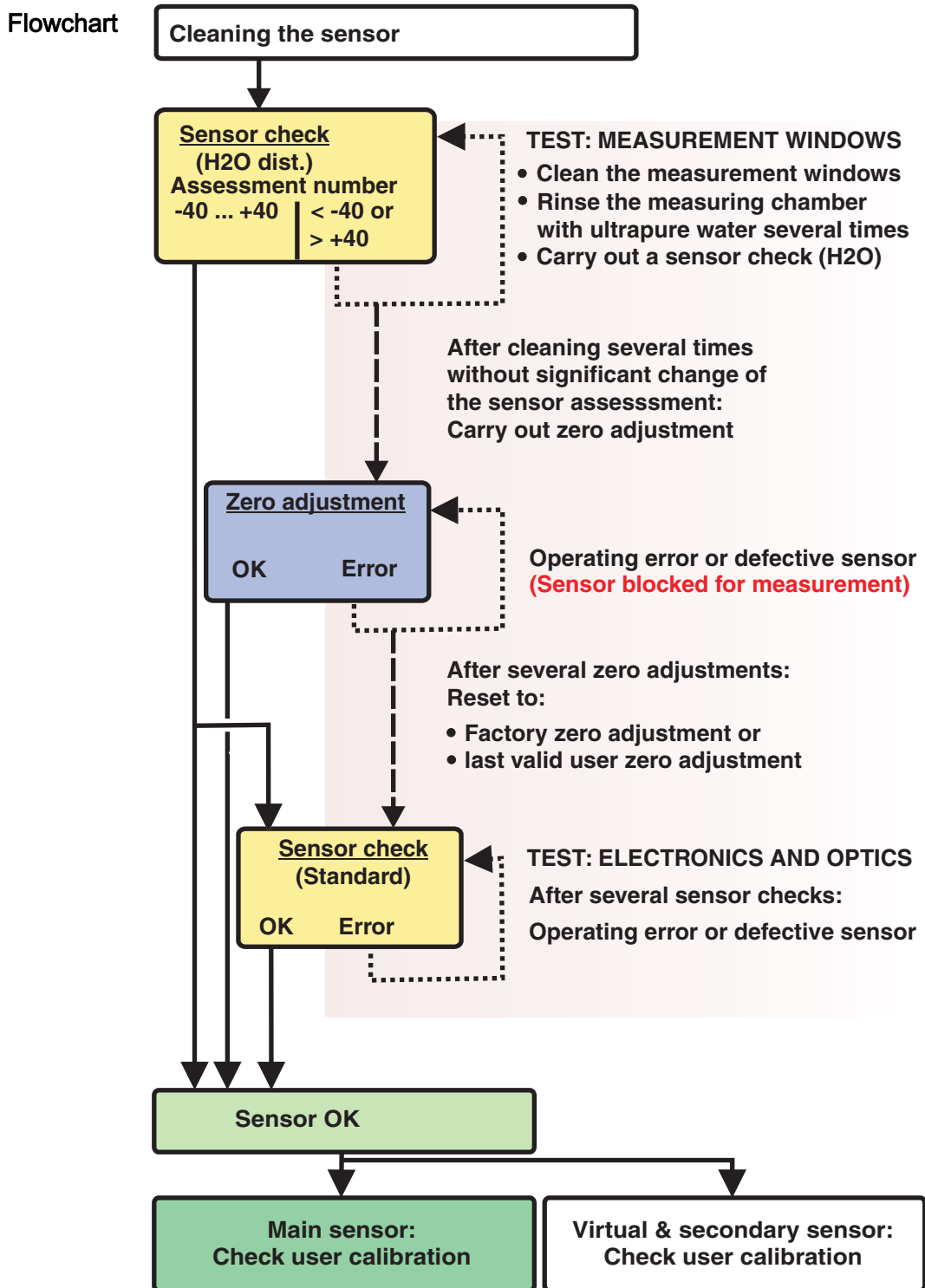

figure 4-3 Overview of Sensortest/Zero adjustment and user calibration.

Preparing the sensor check or Zero adjustment

Prepare the sensor check or *Zero adjustment* as follows:

1. Switch to the measured value display with **<M>**.
2. Use **<▲▼◀▶>** to select the CarboVis 705 IQ TS Co sensor.
3. Call up calibration with **<C>**. The *Wartungszustand: Verknüpfte Ausgänge werden eingefroren.* window appears.



By activating the maintenance condition, linked outputs remain in their present state. The cleaning and the determination of measured values are switched off. The measured value display shows a flashing, invalid measured value ("----").

4. Confirm the maintenance condition with **<OK>**.
5. Take the sensor out of the test sample.
6. Remove the blind plug or unscrew the compressed air connection from the sensor.
7. Thoroughly clean the sensor enclosure, sensor sleeve and the compressed air channels (see section 5.1 MAINTENANCE). To finish the cleaning procedure, thoroughly rinse the entire sensor with ultrapure water.
8. Mount the cleaned sensor sleeve:
 - Loosen both coupling rings on the sensor sleeve.
 - Put the sensor sleeve on the sensor and align it:
 - The measuring gap is in the center of the sensor sleeve
 - The filling opening of the sensor sleeve and the measuring gap opening of the sensor are offset by 90°.
 - Tighten both coupling rings on the sensor sleeve by hand.

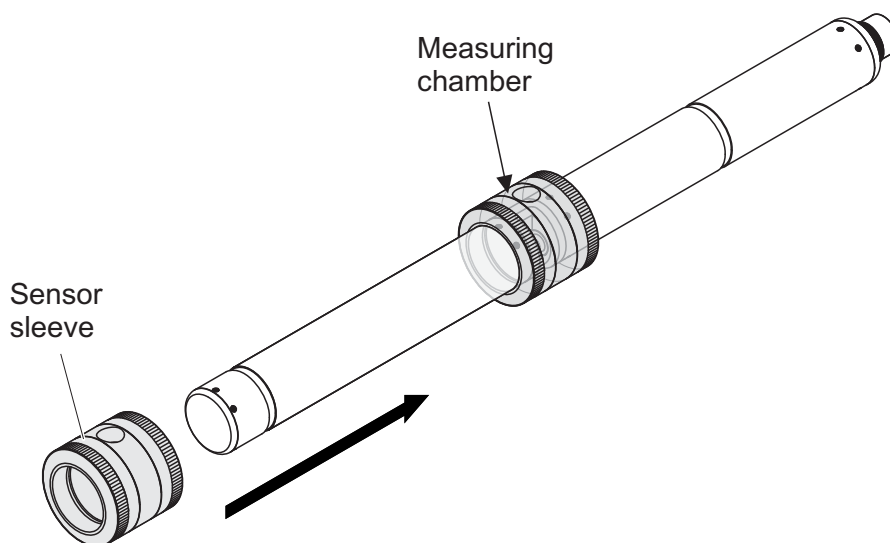

figure 4-4 Putting the sensor sleeve on the sensor

9. Put the sensor in a horizontal position on a firm and vibration-free surface. Turn the filling opening of the sensor sleeve upward (figure 4-4).
10. Rinse the measuring chamber with ultrapure water at least 3 times.
11.
 - For *Sensor check (H₂O dest.)* or *Zero adjustment*.
Fill the measuring chamber with ultrapure water.
 - or
 - For *Sensor check (standard)*.
Fill the measuring chamber with standard solution (see section 6).
12. If there are any air bubbles on the measuring windows remove them by gently knocking on the sensor sleeve with a bar.



Carry out the intended sensor check or *Zero adjustment* directly after filling the sensor sleeve. If you wait longer, the result of the Sensor check/*Zero adjustment* will be affected.

Carrying out the sensor check or Zero adjustment

13. Select the required option with <▲▼◀▶> and <OK>:
 - *Sensor check (H₂O dest.)*
 - *Zero adjustment*
 - *Sensor check (standard)*
14. Confirm with <OK>. A multipart checklist appears. Use it to check once more whether all preparations have been completed.
15. Confirm each checklist with <OK> until the *Start measurement* display appears.



Up to this point, you can break off the calibration procedure at any time with the <ESC> key. The system continues to work with the old calibration data. The maintenance condition, however, has to be switched off again in any case.

After starting the calibration with the <OK> key (step 16.) you can no longer cancel the calibration procedure.

16. Confirm with <OK>.
The measurement is started. After the end of the measurement the result appears. With the *Zero adjustment*, the result is entered in the calibration history at the same time.

Result after Sensor check (H2O dest.)

Rating number	Meaning
Zero range (-40 ... +40)	<i>Sensor check (H2O dest.)</i> successful (OK) (0 = no deviation)
Positive number (+40 ... +1000)	Measured values were too low. <u>Possible cause:</u> The measurement windows are contaminated.
Negative number (-40 ... -1000)	Measured values were too high. <u>Possible cause:</u> During the last zero adjustment, the measurement windows were contaminated more than during the current sensor check.

If the rating number is not in the zero range:

Repeat the cleaning procedure and the *Sensor check (H2O dest.)* until the rating number no longer changes significantly.

If the rating number is still outside the zero range, a new zero adjustment is necessary.

Result after Zero adjustment

Result	Meaning	Sensor released for measurement
OK	<i>Zero adjustment</i> successful.	Yes
Error	<i>Zero adjustment</i> not successful.	No ("----")

If the result is erroneous, clean the sensor and all equipment once again. Then carry out a new *Zero adjustment* and when doing so make sure the conditions are absolutely clean.



If no valid zero adjustment is possible under the current conditions, you can restore the readiness for measurement by measuring with an older valid zero adjustment.

To do so, select the *Zero adjustment* setting in the sensor settings *Factory* (factory zero adjustment) or *User* (last valid user zero adjustment).

Then check the measurement results with a *Sensor check (standard)*. Suitable standards (check equipment) for your sensor are available as accessories (see chapter 6).

Result after Sensor check (standard)

<i>Result</i>	<i>Meaning</i>
<i>OK</i>	<i>Sensor check (standard) successful.</i>
<i>Error</i>	<i>Sensor check (standard) not successful. <u>Possible cause:</u> wrong or expired standard</i>

Completing the sensor check or *Zero adjustment*

After a successful sensor check or *Zero adjustment*, return to measurement as follows:

17. Confirm the calibration result with **<OK>**.
18. Confirm the message, "*After successful cal ...*" with **<OK>**. The display returns to the measured value display. The measured value flashes because the sensor is still in the maintenance condition.
19. Pour away the ultrapure water or standard solution and remove the sensor sleeve.
20. Screw in the blind plug or compressed air connector and install the sensor at the measuring site.
21. After the *Sensor check (standard)*: Thoroughly rinse the sensor and sensor sleeve with ultrapure water.
22. CarboVis 705 IQ TS Co Switch off the maintenance condition (use **<▲▼◀▶>** to select the sensor, press **<OK>** and make the setting in the *Anzeige/Optionen* menu).
23. Switch to the measured value display with **<M>**. The measured value stops flashing.



Store the sensor sleeve in a clean environment, e. g. in a plastic bag, until the next sensor check or *Zero adjustment*.

5 Maintenance and cleaning

5.1 Maintenance

The UV-VIS CarboVis 705 IQ TS Co sensor operates maintenance-free.

5.2 Sensor cleaning

5.2.1 Cleaning agents and accessories

Cleaning agents To clean the sensor, use the following cleaning agents only:

Contamination	Cleaning agents
Water-soluble substances	<ul style="list-style-type: none"> – Primary cleaning: Tapwater, warm if possible (30 - 50 °C) – Precision cleaning: Household washing-up liquid + ultrapure water.
Lime deposits	5 % hydrochloric acid *
Grease deposits	Mixture of isopropanol and water (approx. 70 % isopropanol) *

* For the final cleaning prior to a *Sensor check* or *Zero adjustment*, only use cleaning agents with purity grade "for analysis". Finally, thoroughly rinse the sensor with ultrapure water.

Accessories

- Sponge
- Plastic-bristled brushes of different sizes.
Interdental brushes are suitable for the cleaning of the compressed air channels.
- Flocked cleaning cards (see accessories)
- Lens tissues
- Wash bottle

NOTE

Never use any pressure washer, steam blaster, abrasives or metal brushes to clean the sensor. Risk of damaging the sensor.

5.2.2 General steps to be taken

Depending on the application site and the level of contamination of the sensor as well as the coming job, the cleaning procedure includes the following parts:

- Every cleaning procedure starts with a basic cleaning. It removes tough grime such as incrustation of fouling matter, algae and biological deposits. If the sensor surface might be contaminated with pathogenic germs it should also be disinfected.
- Cleaning the measuring gap: Removal of lime deposits.
- Cleaning the measuring gap: Removal of grease deposits.

Example 1 A heavily soiled sensor for which a *Sensor check* or *Zero adjustment* is to be performed must pass through all cleaning steps thoroughly. During the cleaning process always keep all surfaces moist to prevent already dissolved contamination and detergents from drying ("working wet-on-wet"). Finally, thoroughly rinse off all remaining cleaning agents with ultrapure water.

Example 2 If the sensor from example 1 should be cleaned on site during a routine visual inspection and should then continue measuring, a basic cleaning might possibly be sufficient.



The quoted examples and the following descriptions are intended to give a general guideline. Due to the sensor's wide range of application, the type and level of contamination can considerably vary. Therefore, the cleaning procedure has to be individually composed. If necessary, individual cleaning steps have to be changed or repeated several times until the result meets the requirements.

5.2.3 Basic cleaning

Steps of the basic cleaning

1. Take the sensor out of the test sample and remove any solid matter deposits and incrustation of fouling matter manually with a brush or sponge.
2. Wash the sensor down with warm tapwater (30 - 50 °C).
Note: Do not use a pressure washer or steam blaster.
3. If the sensor might be contaminated with pathogenic germs it should be disinfected with a surface disinfectant. This also applies to the cable and mounting parts.
Note: Follow the instruction manual of the disinfectant (reaction time!).
4. Remove the blind plug or unscrew the compressed air connection from the sensor.
5. Clean the sensor with soapy water. When doing so, clean the area of the measuring gap and the compressed air channels very thoroughly. The compressed air channels can be cleaned with the aid of interdental brushes and rinsed with soapy water from a wash bottle.
6. Soak the flocked cleaning cards with soapy water and use them to clean the measuring gap as shown in the following figure. Cut suitable strips off the cleaning card to clean the bottom of the measuring gap. Then rinse the sensor with running warm tapwater and finally with a lot of ultrapure water.
7. Finally wipe the measurement window with a lens tissue.

After completing the cleaning procedure, screw in the blind plug or compressed air connection.

5.2.4 Cleaning the measuring gap

To remove lime or grease deposits, use the flocked cleaning cards together with the following detergents:

Contamination	Cleaning agents
Lime deposits	Hydrochloric acid 5 % for analysis
Grease deposits	Mixture of isopropanol and water (approx. 70 % isopropanol), made of 7 volume parts isopropanol for analysis and 3 volume parts ultrapure water

Proceeding

- Start by removing any lime deposits.
- Soak a flocked cleaning card with the relevant detergent and use it to clean the measuring windows according to step 6. in section 5.2.3 BASIC CLEANING. If necessary, leave the cleaning card in the measuring gap for a few minutes so the detergent can take effect.

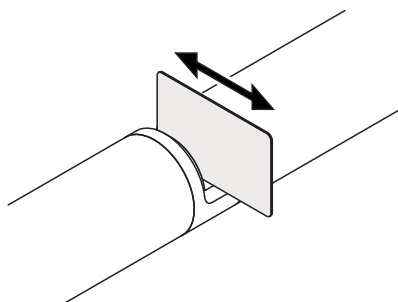

- Thoroughly rinse with ultrapure water the measuring gap and the surrounding areas moistened with detergent.
- Then wipe the measurement window with a lens tissue. The surface of the measurement windows must be free of streaks.
- Protect the cleaned sensor against new contamination.

6 Spare parts, maintenance equipment, accessories

General accessories, replacement parts	Description	Model	Order no.
	Calibration sleeve	VIS/CV	481 074
	20 flocked cleaning cards for cleaning the measuring gap	VIS/CT	481 071
	Cleaning set: – 20 flocked cleaning cards – Cleaning solutions	VIS C/SET	481 079
Test equipment	Description	Model	Order no.
	Standard 1 with low concentration for 5 mm sensors	ST-1	481 077
	Standard 2 with high concentration for 1 mm UVVIS/SAC/NO _x sensors	ST-2	481 078
Components for the optional compressed air cleaning system	Description	Model	Order no.
	Compressed air cleaning set with 15 m compressed-air hose, to be connected to a valve module or Cleaning Air Box	SET/AP	481 075
	Active valve module (does not require a free relay output in the IQ SENSOR NET system)	MIQ/CHV PLUS	480 018
	Valve module for the IQ SENSOR NET system 182 (external relay and compressed air supply)	DIQ/CHV	472 007
	Air compressor to be triggered by relay, power supply 115 V AC	Cleaning Air Box - 115 VAC	480 017
	Air compressor to be triggered by relay, power supply 230 V AC	Cleaning Air Box - 230 VAC	480 019

Mounting accessories	Description	Model	Order no.
	Mounting set for horizontal installation with EH/F 170 swing mounting assembly	VIS Set/EH	481 073
	Set for the mounting of UVVIS/SAC/NOx sensors to the S 200 electrode floater	VIS Set/F	481 080
	Flow-through armature	VIS FT-1	480 080



Information on further IQ SENSOR NET accessories is given in the WTW catalog and on the Internet.

7 What to do if...

"----" display (invalid measured value)	Cause	Remedy
	<ul style="list-style-type: none"> - User calibration values entered incorrectly - * <i>Sensor check (H2O dest.)</i> or * <i>Zero adjustment</i> or * <i>Sensor check (standard)</i> defective 	<ul style="list-style-type: none"> - Correct the entry and enter once again (section 4.3.2) - Repeat * <i>Sensor check (H2O dest.)</i> or * <i>Zero adjustment</i> or * <i>Sensor check (standard)</i> - Check conditions, especially cleanliness (section 4.3.3)
	<ul style="list-style-type: none"> - <i>Zero adjustment</i> still erroneous after several trials 	<ul style="list-style-type: none"> - Contact the service department
	<ul style="list-style-type: none"> - Unknown 	<ul style="list-style-type: none"> - See log book
Implausible measured values	Cause	Remedy
	<ul style="list-style-type: none"> - Erroneous user calibration 	<ul style="list-style-type: none"> - Repeat user calibration. Make sure the samples for comparison are representative.
	<ul style="list-style-type: none"> - Substantial change of test sample (sample matrix) 	<ul style="list-style-type: none"> - Carry out new user calibration
	<ul style="list-style-type: none"> - Measurement windows dirty 	<ul style="list-style-type: none"> - Clean the measurement windows
	<ul style="list-style-type: none"> - Sensor setting wrong 	<ul style="list-style-type: none"> - Check and, if necessary, correct the <i>Measuring mode, Measuring location</i> sensor settings - Carry out new user calibration
	<ul style="list-style-type: none"> - Optical system maladjusted, e. g. due to inadmissible mechanical shock 	<ul style="list-style-type: none"> - Carry out * <i>Sensor check (H2O dest.)</i> or * <i>Zero adjustment</i> or * <i>Sensor check (standard)</i>

Drifting measured values	Cause	Remedy
	– Cleaning efficiency too low - measurement windows becoming more and more contaminated	<ul style="list-style-type: none"> – Clean the measurement windows (section 5.2.4) – Use other cleaning method – Select different measurement location – Set longer cleaning duration – Set more frequent cleaning procedures – Install optional compressed air cleaning device
	– Failure of the optional compressed air cleaning system	<ul style="list-style-type: none"> – Clean the measurement windows (section 5.2.4) – Check all components of the compressed air cleaning system (compressor, compressed air line, sensor, rinsing openings)
	– Substantial change of test sample (sample matrix)	– Carry out new user calibration
Display of <i>OFL</i>	Cause	Remedy
	– Measuring range exceeded	– Check process
	– Foreign matter in the measuring gap	– Clean the measuring gap (section 5.2.3)
	– Erroneous user calibration	– Repeat user calibration. Make sure the samples for comparison are representative.
Measured values fluctuating strongly	Cause	Remedy
	– Gas bubbles in front of the measurement windows	– Check the position within the process and the installation position
Measured values too low or too high	Cause	Remedy
	– Gas bubbles in front of the measurement windows	– Check the installation position of the sensor

	Cause	Remedy
	<ul style="list-style-type: none"> - Measurement windows dirty 	<ul style="list-style-type: none"> - Clean the measurement windows
Display of <i>ERROR</i>	<ul style="list-style-type: none"> - Sensor not correctly connected 	<ul style="list-style-type: none"> - Check the assignment of the terminal connections
	<ul style="list-style-type: none"> - Load at a power supply module too high 	<ul style="list-style-type: none"> - Install another power supply module in the vicinity of the sensor
	<ul style="list-style-type: none"> - IQ SENSOR NET cable towards the CarboVis 705 IQ TS Co too long (voltage drop too great) 	<ul style="list-style-type: none"> - Install another power supply module in the vicinity of the sensor
	<ul style="list-style-type: none"> - Electrical connection between power supply module and CarboVis 705 IQ TS Co is interrupted 	<ul style="list-style-type: none"> - Check the cable connection step-by-step starting with the power supply module, and replace any defective cable sections. - Check the contacts on the MIQ modules (stack mounting). Clean any dirty contacts. Carefully bend back contact springs that have been pressed flat or bent (pay attention to sufficient spring tension)

8 Technical data

8.1 Measurement characteristics

Measuring principle Spectrophotometric absorption measurement; integrated microprocessor electronics, shielded 2-wire connection for power and data transmission.

Light source Lamp type | Xenon flashlamp

Detector Photo diodes | 256

Wavelengths range 200 - 720 nm

Measuring gap (optical layer thickness) 5 mm

Carbon measurement, 5 mm gap width	Measuring location	Measuring mode	Measuring range	Resolution
	<i>Outlet</i>	<i>COD spectr., total</i>	0.0 ... 800.0 mg/L	0.1 mg/L
	<i>COD spectr., dissolv</i>	0.0 ... 800.0 mg/L	0.1 mg/L	
	<i>TOC spectr., correl.</i>	0.0 ... 500.0 mg/L	0.1 mg/L	
	<i>DOC spectr., correl.</i>	0.0 ... 500.0 mg/L	0.1 mg/L	
	<i>BOD spectr., correl.</i>	0.0 ... 500.0 mg/L	0.1 mg/L	
	<i>SAC 254, total</i>	0.0 ... 600.0 1/m	0.1 1/m	
	<i>SAC 254, dissolved</i>	0.0 ... 600.0 1/m	0.1 1/m	
	<i>UVT 254, total*</i>	0.0 ... 100.0 %	0.1 %	
	<i>UVT 254, dissolved*</i>	0.0 ... 100.0 %	0.1 %	

* The UVT-254 value is standardized to 10 mm gap width.

TSS measurement, 5 mm gap width	Measuring location	Measuring mode	Measuring range	Resolution
	<i>Outlet</i>	<i>TSS</i>	0.0 ... 900.0 mg/L	0.1 mg/L

Measurement of the coloration 5 mm gap width	Measuring location	Measuring mode	Measuring range	Resolution	
	Outlet	Hazen 340		8 ... 1050 mg/l Pt/Co	1
		Hazen 350		8 ... 1150 mg/l Pt/Co	1
		Hazen 390		8 ... 2100 mg/l Pt/Co	1
		Hazen 445		150 ... 10000 mg/l Pt/Co	1
		Hazen 455		150 ... 10000 mg/l Pt/Co	1
		Hazen 465		150 ... 10000 mg/l Pt/Co	1
		ISO 410		20 ... 5300 mg/l Pt/Co	1



With the wavelengths 340 nm, 350 nm, 390 nm, and 410 nm, the display ranges are extended to 0 at the lower measuring range limits.



The quoted measuring ranges are nominal measuring ranges that are theoretically possible. In practice, real measuring ranges exist that are given by the limits of photometric determination. The limits are significantly influenced by the light scattering due to solids and the absorption of accompanying substances (sample matrix). Therefore, no fixed measuring range can be determined beforehand.

8.2 Application characteristics

Suitability and ranges of application

Municipal wastewater with a low proportion of industrial wastewater

Municipal wastewater with a low proportion of industrial wastewater, waste water treatment plants, surface water

Measuring medium

pH value	4 - 12
Flow rate	< 3 m/s
Temperature	0 °C ... + 45 °C (32 °F ... + 113 °F)

Pressure resistance

Sensor with connected SACIQ (SW) sensor connection cable:

Max. allowed overpressure	105 Pa (1 bar)
---------------------------	----------------

The sensor meets all requirements according to article 3(3) of 97/23/EC ("pressure equipment directive").

Type of protection Sensor with connected SACIQ (SW) sensor connection cable:
IP X8, 1 bar (10⁵ Pa)

Immersion depth	min	The measuring gap must be filled with test sample.
	max	10 m depth

Operating position Any

8.3 General data

Dimensions (in mm)

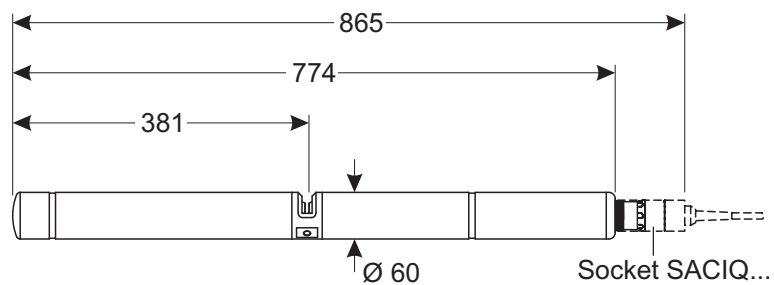

With shock protection:

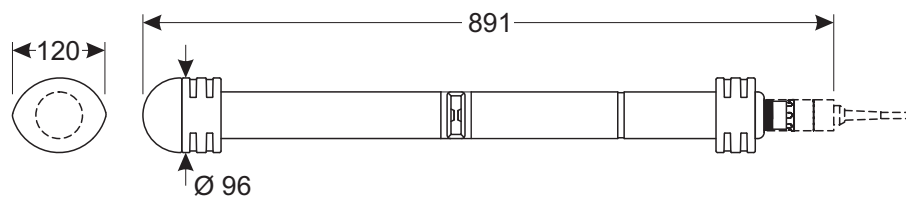

Weight Approx. 3.8 kg (without shock protectors and without sensor connection cable)
Approx. 4.8 kg (with shock protectors but without sensor connection cable)

Connection technique Connection via SACIQ (SW) sensor connection cable

Materials	Sensor shaft	Titan Grade 2
	Center piece	PEEK
	End cap	PEEK
	Measurement window	Sapphire
	Plug head connector housing	POM
	Plug, 3-pole	ETFE (blue) Tefzel®
	Protection ring	POM

Storage temperature - 10 °C ... + 50 °C (14 ... 122 °F)

Meter safety	Applicable norms	- EN 61010-1
		- UL 61010-1
		- CAN/CSA C22.2#61010-1
		- IEC 62471

Test certificates cETLus, CE, UKCA



Conforms to ANSI/UL 61010-1
 Certified to CAN/CSA C22.2#61010-1"

Intertek

2001759

8.4 Electrical data

Nominal voltage	Max. 24VDC via the IQ SENSOR NET (for more details, see chapter TECHNICAL DATA of the IQ SENSOR NET system operating manual)
Power consumption	8 W (maximum power consumption) 3.5 W (medium power consumption) If the power is supplied via an MIQ/WL PS or a DIQ/S 28X, only the medium power consumption should be taken into account.
Protective class	III

9 Indexes

9.1 Explanation of the messages

This chapter contains a list of all the message codes and related message texts that can occur in the log book of the IQ SENSOR NET system for the CarboVis 705 IQ TS Co sensor.



Information on the contents and structure of the log book and the structure of the message code is given in the LOG BOOK chapter of the IQ SENSOR NET system operating manual.

The last three digits of the message code form the component code. It identifies the component (active component) that caused the message:

Some error messages contain an internal error code, starting with "#".

Module code	Component
3A4	CarboVis 705 IQ
3A8	SolidVis 705 IQ
3AF	ColorVis 705 IQ
3A19	ColorVis 705 IQ - virtual
3AW	CarboVis 705 IQ - virtual
3AX	CarboVis 705 IQ - virtual
541	BasicVis IQ

9.1.1 Error messages

Message code	Message text
EA2541	<i>Sensor temperature too high!</i> <i>* Check process and application</i>
EA3541	<i>Sensor temperature too low!</i> <i>* Check process and application</i>
EAF541	<i>Optical measuring range exceeded</i> <i>* Check process (TSS or measured value too high)</i> <i>* Select measuring location free of air bubbles</i> <i>* Remove foreign matter from measuring gap</i> <i>* Clean sensor</i> <i>* Optimize cleaning settings</i> <i>* Switch on signal smoothing, increase response time</i>
EAI541	<i>Zero adjustment erroneous</i> <i>* Clean the sensor and sensor sleeve repeatedly</i> <i>* Position the sensor sleeve according to operating manual</i> <i>* Rinse the measuring chamber with ultrapure water several times</i> <i>* Fill the measuring chamber with ultrapure water</i> <i>* Repeat the zero adjustment</i>
EAM3Ax	<i>Meas. range exceeded or undercut</i> <i>* Check process</i>
EC33Ax	<i>User calibration erroneous,</i> <i>Check raw value / reference value pairs:</i> <i>* Set all values within the measuring range</i> <i>(see operating manual)</i> <i>* Enter value pairs in ascending order</i>
EI1541	<i>Operational voltage too low</i> <i>* Check installation and cable lengths, Follow installation instructions</i> <i>* Power supply module(s) overloaded, add power supply module(s)</i> <i>* Check terminal and module connections</i> <i>* Defective components, replace components</i>
EI2541	<i>Operational voltage too low, no operation possible</i> <i>* Check installation and cable lengths, Follow installation instructions</i> <i>* Power supply module(s) overloaded, add power supply module(s)</i> <i>* Check terminal and module connections</i> <i>* Defective components,</i> <i>replace components</i>
ES2541	<i>Humidity too high in sensor</i> <i>* Contact service</i>
ES3541	<i>Failure optical measurement: deviation in reference channel too high</i> <i>* Execute zero adjustment</i>

Message code	Message text
ES4541	<i>Overflow optical measurement * Execute zero adjustment</i>
ES5541	<i>Failure optical measurement: hardware * Contact service</i>
ES6541	<i>Failure optical measurement: software * Contact service</i>
ES7541	<i>Failure optical measurement: software BIOS * Contact service</i>

9.1.2 Informative messages

Message code	Message text
IA23Ax	<i>Calculation of negative concentrations * Perform user calibration or check user calibration</i>
IAC541	<i>Zero adjustment was successfully carried out * Carry out sensor check * If required, carry out new user calibration</i>
IC3541	<i>The factory zero adjustment was activated. Make sure the sensor operates correctly.</i>
IC4541	<i>The last valid user zero adjustment was activated. Make sure the sensor operates correctly.</i>
IC5541	<i>Invalid user zero adjustment was replaced by last valid user calibration. Caution! Wrong measured values possible. Carry out a new successful zero adjustment to make sure the sensor operates correctly.</i>
IC6541	<i>The invalid user zero adjustment was replaced by the factory zero adjustment. Caution! Wrong measured values possible. Check whether the sensor operates correctly or carry out a new successful user zero adjustment.</i>

9.2 Status info

The status info is a coded piece of information on the current status of a sensor. Each sensor sends this status info to the controller. The status info of sensors consists of 32 bits, each of which can have the value 0 or 1.

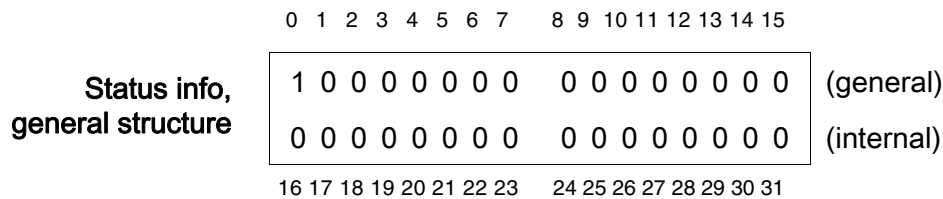

The bits 0 - 15 are reserved for general information.
 The bits 16 - 21 are reserved for internal service information.

You obtain the status info:

- via a manual query in the *Settings/Service/ List of all components* menu (see system operating manual)
- by an automated query
 - of a superordinate process control (e. g. when connected to the Profibus)
 - of the IQ Data Server (see operating manual of the IQ SENSOR NET software pack)



The evaluation of the status info, e.g. in the case of an automated query, has to be made individually for each bit.

Status-Info CarboVis 705 IQ TS Co	Status bit	Explanation
	Bit 0	<i>Component hardware defective</i>
	Bit 1	<i>Component hardware defective xxx</i>
	Bit 2	<i>Optical measuring range exceeded</i>
	Bit 3-31	-

10 Appendix: Glossary

Absorbance (Absorption)	Attenuation of the light beam when it penetrates the sample.
Adjusting	To manipulate a measuring system so that the relevant value (e. g. the displayed value) differs as little as possible from the correct value or a value that is regarded as correct, or that the difference remains within the tolerance.
Calibration	Comparing the value from a measuring system (e. g. the displayed value) to the correct value or a value that is regarded as correct. Often, this expression is also used when the measuring system is adjusted at the same time (see adjusting).
Calibration value pair	Value pair consisting of the raw value measured by the CarboVis 705 IQ TS Co sensor, and a reference value measured e.g. by a laboratory determination. The calibration value pairs are the result of the user calibration.
Concentration	Mass or amount of a dissolved substance per volume, e. g. in g/L or mol/L.
Measured parameter	The measured parameter is the physical dimension determined by measuring, e. g. pH, conductivity or D.O. concentration.
Measured value	<p>The measured value is the special value of a measured parameter to be determined. It is given as a combination of the numerical value and unit (e. g. 3 m; 0.5 s; 5.2 A; 373.15 K).</p> <p>The measured value is determined from the raw value taking into account the data from a user calibration. The measured value is displayed together with the raw value in the measured value display.</p>
Measuring gap	The measuring gap is between the two measurement windows. In the measuring gap, the light beam penetrates the test sample.
Measuring system	The measuring system comprises all the devices used for measuring, e. g. measuring instrument and sensor. In addition, there is the cable and possibly an amplifier, terminal strip and armature.
Reference sample	Random sample of the test sample for comparative chemical-analytical laboratory analyses intended for user calibration.
Resolution	Smallest difference between two measured values that can be displayed by a meter.
Sample matrix	Composition of the test sample of different individual substances.
Test sample	Designation of the test sample ready to be measured.
Ultrapure water (H₂O dist.)	Ultrapure water is distilled or deionized water suitable for analysis purposes.

Xylem |'zīləm|

- 1) The tissue in plants that brings water upward from the roots;
- 2) a leading global water technology company.

We're a global team unified in a common purpose: creating advanced technology solutions to the world's water challenges. Developing new technologies that will improve the way water is used, conserved, and re-used in the future is central to our work. Our products and services move, treat, analyze, monitor and return water to the environment, in public utility, industrial, residential and commercial building services settings. Xylem also provides a leading portfolio of smart metering, network technologies and advanced analytics solutions for water, electric and gas utilities. In more than 150 countries, we have strong, long-standing relationships with customers who know us for our powerful combination of leading product brands and applications expertise with a strong focus on developing comprehensive, sustainable solutions.

For more information on how Xylem can help you, go to xylem.com.



Service and Returns:

Xylem Analytics Germany
Sales GmbH & Co. KG
WTW
Am Achalaich 11
82362 Weilheim
Germany

Tel.: +49 881 183-325
Fax: +49 881 183-414
E-Mail wtw.rma@xylem.com
Internet: www.WTW.com



Xylem Analytics Germany GmbH
Dr.-Karl-Slevogt-Str. 1
82362 Weilheim
Germany