



Models 30570-0XXX
30570-1XXX

SELF-PRIMING PUMPS

FEATURES

Pump Type:	Pedestal Pump
Body:	316 Stainless Steel
Impeller:	Neoprene or EPDM
Shaft Seal:	Mechanical; Carbon-on-Ceramic or Tungsten Carbide; Nitrile
Ports:	1-1/2" ACME Threads with Bevel Seat or Clamp Type
Shaft:	316 Stainless Steel
Weight:	21.0 lb (9.5 kg) Approx.

APPLICATIONS

DAIRY: Transfer and processing of raw milk, cream, milk whey, buttermilk, condensed milk.

FOODS: Processing of eggs, sugar liquors, brines, catsup, chocolate, glaze, gelatin, honey, jams, jellies, mayonnaise, molasses, mustard, pickle relish, vinegar, water, yeast slurries, syrups, liquids containing solids in suspension such as chopped tomatoes, nuts, peanut butter.

BEVERAGE: Circulating and transferring alcohols, beers, brewery slop, cider, distillery wort, extracts, flavors, juice, mash, soft drink syrups, wines.

PHARMACEUTICAL: Moving medicines, cosmetics, process chemicals, lotions, preparations, filtering solutions, used as a filling line supply pump.

N.B. 3A option to include Elastomers : EPDM and Neoprene. Ports : Tri-Clamp, IDF, 3A and DIN11851.

	WARNING Explosion hazard. Do not pump gasoline or other flammable liquids. To do so can cause an explosion resulting in injury or death.
---	--

OPERATING INSTRUCTIONS

1. **INSTALLATION** – Pump may be mounted in any position. The rotation of the pump shaft determines the location of the pump's intake and discharge ports. (Refer to dimensional drawing.) Pump is normally assembled at factory for clockwise rotation looking at end cover. If counterclockwise rotation is desired, follow steps 1 and 2 of disassembly and

	WARNING Injury hazard. Exposed pulleys and belts can cause injury. Install shield around pulleys and belts. Stay clear while machinery is operating.
---	--

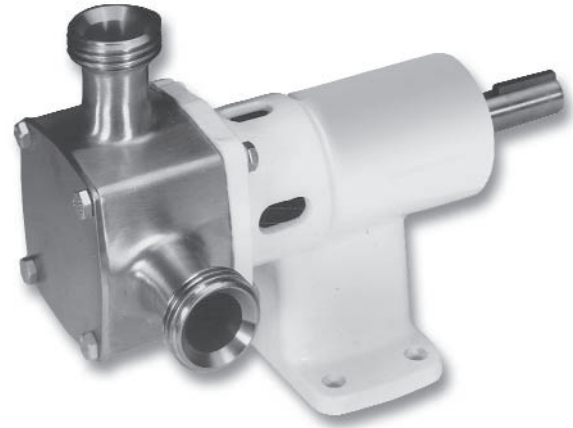

Models 30570-0XXX, 30570-1XXX

VARIATIONS AVAILABLE

Model	Description
30570-0005	Standard Pressure, Neoprene Impeller, Carbon Seal, ACME Ports
30570-0015	High Pressure, Neoprene Impeller, Carbon Seal, ACME Ports
30570-0105	Standard Pressure, Neoprene Impeller, Tungsten Carbide Seal, ACME Ports
30570-0115	High Pressure, Neoprene Impeller, Tungsten Carbide Seal, ACME Ports
30570-1005	Standard Pressure, Neoprene Impeller, Carbon Seal, Clamp Ports
30570-1015	High Pressure, Neoprene Impeller, Carbon Seal, Clamp Ports
30570-1105	Standard Pressure, Neoprene Impeller, Tungsten Carbide Seal, Clamp Ports
30570-1115	High Pressure, Neoprene Impeller, Tungsten Carbide Seal, Clamp Ports

step 9 of assembly instructions to change direction of impeller blade deflection under cam.

2. **DRIVE** – Belt or direct with flexible coupling.

Belt Drive: Overtight belt load will reduce pump bearing life.

Direct Drive: Clearance should be left between drive shaft and pump shaft when installing coupling.

Always mount and align pump and drive shaft before tightening the coupling set screw.

If pulley or coupling must be pressed on shaft, remove end cover and impeller to support shaft from impeller end during press operation. Do not hammer pulley or coupling on shaft; this may damage bearing or seal.

Three phase capacitor start motor is required to overcome starting torque of impeller.

3. **SPEEDS** – 100 RPM to the maximum shown in the performance curves. For longer pump life, operate at lowest possible speeds. Lower speeds are required for viscous liquids. Consult the factory for proper speeds and horsepower requirements.
4. **SELF-PRIMING** – Primes at low or high speeds. For vertical dry suction lift of 10 feet (neoprene) – 8 feet (EPDM), a minimum of 860 RPM is required. Pump will produce suction lift up to 22 feet when wet.
BE SURE SUCTION LINES ARE AIRTIGHT OR PUMP WILL NOT SELF-PRIME.
5. **DISCHARGE** – When transferring liquids further than 25 feet, use one size larger discharge line than discharge port size.
6. **RUNNING DRY** – Unit depends on liquid pumped for lubrication. DO NOT RUN DRY for more than 30 seconds. Lack of liquid will damage the impeller.
7. **PUMPAGE COMPATIBILITY** – Consult the Chemical Resistance Guide in the JABSCO Industrial Pump Catalog (available upon request from the factory) for proper body materials and impeller compounds. If corrosive fluids are handled, pump life will be prolonged if pump is flushed with a neutralizing solution after each use or after each work day. A Tungsten Carbide Seal variation is available for pumping liquids that contain abrasives or are highly corrosive.
8. **PRESSURES** – Consult Performance Curves for maximum recommended pressures for pump in continuous operation. If pressures exceed those shown, consult the factory.
9. **TEMPERATURES** – The operating temperature limits of the pump depend on the impeller compound. The following ranges apply:
Neoprene - 45° to 150° F (7° to 65° C)
EPDM - 45° to 185° F (7° to 85° C).
10. **CLEANING** – Before using pump, it should be disassembled and cleaned to remove any dust and dirt resulting from storage or shipping. Wash parts in standard cleaning solutions approved for handling stainless steel. Thoroughly rinse before reassembly.
DO NOT USE IODINE BASED SANITIZERS as the iodine attacks the elastomer materials used in the impeller.

N.B. Do not clean with Phosphoric Acid.

All parts have been expertly machined and polished. HANDLE WITH CARE. DO NOT DROP OR MISHANDLE.

11. **IMPELLER TORQUE** – The torque required to initiate rotation of a new impeller in a dry pump body is:
Standard Pressure Impeller (14346-Series):
Forward = 14.5 pounds force – feet
Reverse = 43.0 pounds force – feet
High Pressure Impeller (8983-Series):

Forward = 26.0 pounds force – feet
Reverse = 40.0 pounds force – feet

These values may vary slightly due to impeller compounding, blade set, and body material of construction. Consult factory for more information.

12. **SPARE PARTS** – To avoid costly shutdowns, keep a spare JABSCO impeller, seal and O-ring set on hand.

SERVICE INSTRUCTIONS

DISASSEMBLY

1. Remove the four end cover screws. Remove end cover and O-ring.
2. Remove the four screws, holding the body to the bearing housing flange. Slide body, complete with impeller and wearplate, from pedestal and shaft assembly.
3. Remove mechanical seal by inserting two screwdrivers behind seal collar, and gently lever collar and seal assembly forward on shaft. Use extreme care not to mar shaft surface. Remove seal seat and rubber cup from recess in wearplate.
4. From the drive end of the bearing housing, pry out bearing seal by inserting a screwdriver blade between OD of the seal and housing. Remove retaining ring. Very carefully withdraw shaft and bearing assembly.
5. Remove inner bearing seal and retaining ring.
6. To remove bearings from shaft, an arbor press is required. If an arbor press is not available then a bearing extractor may be used. Supporting inner race of bearing, apply a steady pressure on shaft until bearing slides free. Repeat this procedure to remove second bearing.

ASSEMBLY

1. To replace bearing on shaft. Support ball bearing on its inner race and locate shaft onto bearing. Apply a steady pressure to the shaft until bearing locates against shoulder on shaft. Repeat for second bearing.
2. Fit retaining ring and bearing seal into impeller end of bearing housing. Spring on bearing seal to face outwards.
3. Apply bearing grease around and between bearings, filling cavity between bearings two thirds full. Smear grease on shaft where bearing seal locates. Push shaft and bearing assembly into bearing housing.
4. Replace retaining ring and outer bearing seal with spring facing outwards.
5. Replace mechanical seal by sliding spacer onto shaft up to locating shoulder, then smear shaft with light lubricating oil. Push on seal gently until it engages with spacer. Fit rubber cup and seal seat into wearplate.
6. Insert impeller in pump body, fit O-ring in each end of the pump body. Fit wearplate to body.
7. Slide wearplate and body assembly over shaft, position wearplate in housing. Fit body to pedestal with screws. Torque screws to 10 in. – lbs.

NOTE: A gap should be maintained between bearing housing and body. DO NOT overtighten screws.

8. Fit end cover and end cover screws. Torque screws to 10 in. – lbs.

9. Changing Pump Rotation (looking at end cover):

Clockwise Rotation:

Insert impeller into pump body with blades bending counterclockwise

Counterclockwise Rotation:

Insert impeller into pump body with blades bending clockwise.

PARTS LIST

Key	Description	Qty.	Part Number
1	Bearing Housing	1	18753-0185
2	Body:	1	
	2-A. Clamp Ports		18753-0365
	2-B. ACME Ports		18753-0366
3	End Cover	1	18753-0367
4	Wearplate	1	18753-0201
5	Shaft	1	18753-0207
6	Impeller:	1	
	Standard Pressure - Neoprene		14346-0005
	Standard Pressure - EPDM		14346-0002
	High Pressure - Neoprene		8983-0005
	High Pressure - EPDM		8983-0002
7	Spacer	1	18753-0228
8	Seal Seat:	1	
	Ceramic - Nitrile		18753-0237
	Tungsten Carbide - Nitrile		18753-0239
9	Seal Mech.:	1	
	Ceramic - Nitrile		18753-0249
	Tungsten Carbide - Nitrile		18753-0251
10	Bearing Seal	2	18753-0259
11	O-Ring: Nitrile	2	18753-0265
12	Retaining Ring	2	18753-0271
13	Bearing	2	18753-0275
14	Screw Kit:	1	18753-0285
	Consists of		
	Screw, Hex Hd. M8x20mm (4)		
	Screw, Pan Hd. M8x14mm (4)		
	Washer, Flat M8 (4)		

EXPLODED VIEW

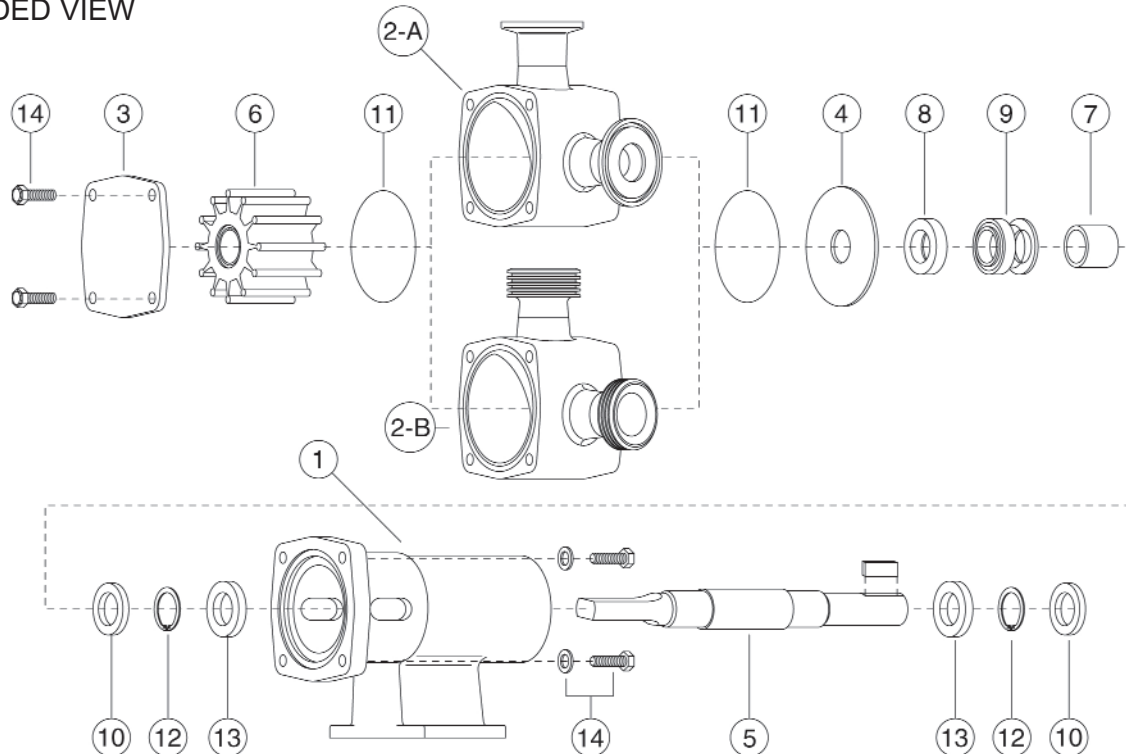

DIMENSIONAL DRAWINGS

Inches (Millimeters)

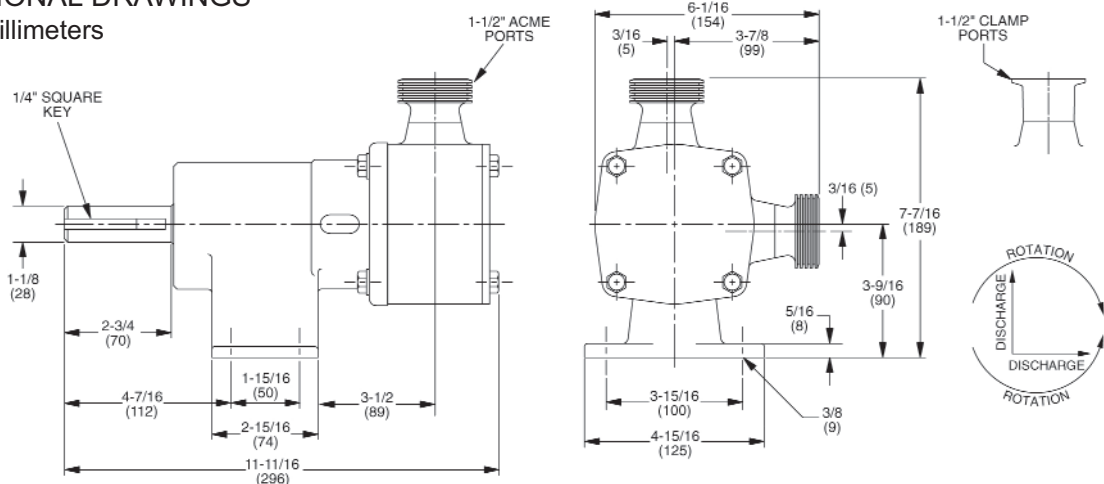

PERFORMANCE CURVES

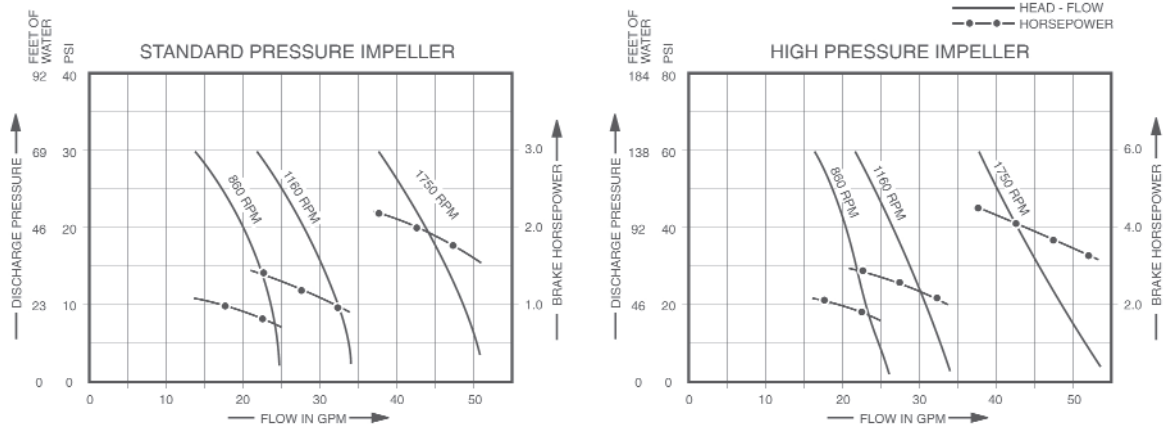

NOTE: Curves show approximate head flow for new pumps with neoprene impeller pumping water. Capacities should be reduced approximately 20% with high pressure EPDM impeller.

PUMP SPEED SELECTION ACCORDING TO PRODUCT VISCOSITY

Viscosity S.S.U.	Pump Speed (Max. RPM)	Viscosity S.S.U.	Pump Speed (Max. RPM)	Viscosity S.S.U.	Pump Speed (Max. RPM)	Viscosity S.S.U.	Pump Speed (Max. RPM)
50	1750	700	1680	4,000	1400	15,000*	787
100	1750	800	1645	5,000	1312	20,000*	700
200	1750	900	1610	6,000	1225	30,000*	612
300	1750	1,000	1575	7,000	1138	40,000*	525
400	1750	1,500	1540	8,000	1050	50,000*	437
500	1750	2,000	1505	9,000	962	75,000*	298
600	1715	3,000	1450	10,000	875	100,000*	175

Consult factory for specific performance information. *Use High Pressure Impeller.

xylem
Let's Solve Water

Jabco, 1 Kondelin Road, Cape Ann Industrial Park, Gloucester, MA 01930
Tel: +1 978 281 0440 Fax: +1 978 283 2619

USA

Jabco, Bingley Road, Hoddesdon, Hertfordshire, FN11 0BU
Tel: +44 (0) 1992 450 145 Fax: +44 (0) 1992 467 132

UK

NHK Jabco Co Ltd, 3-21-10, Shin - Yokohama Kohoku-ku, Yokohama 222
Tel: +81 (0) 45 475 8906 Fax: +81 (0) 45 475 8908

JAPAN

Jabco GmbH, Ostraße 28, 22844 Norderstedt
Tel: +49 (0) 40 53 53 73 0 Fax: +49 (0) 49 53 53 73 11

GERMANY

Jabco Italia, s.r.l., Via Tommaso, 6, 20059 Vimercate, Milano
Tel: +39 039 685 2323 Fax: +39 039 666 307

ITALY

Warranty: All products of the company are sold and all services of the company are offered subject to the company's warranty and terms and conditions of sale, copies of which will be furnished upon request. The information provided herein is for guidance only, it does not constitute a guarantee of the performance or specification of any individual product or component.
© 2012 Xylem, Inc. All rights reserved. JABSCO is a registered trademark of Xylem Inc. or one of its subsidiaries.