

# Adaptive N<sup>®</sup> impeller solves clogging issues for small-range wastewater pumps

## Enhances self-cleaning capabilities where torque is limited

Clogging is the most common problem in wastewater pumping and a particular issue for small pumps due to their limited hydraulic space and lower torque. The consequences of clogging include increased energy consumption, additional maintenance, and emergency call-outs, all of which result in higher operating costs. Wastewater pump manufacturers are continually striving to develop improved hydraulics that reduce clogging while maintaining high performance.

The Adaptive N hydraulic design, an evolution of self-cleaning N-hydraulics to address the challenges of small pumps, offers a marked improvement in pump system stability, with reduced costs for energy consumption and unplanned maintenance.

Adaptive N impeller pumps can be installed in screened and unscreened sewage stations, pumping wastewater from households, commercial buildings, hospitals, schools, and more. They can also be used in industrial effluent and stormwater run-off that may carry solids, fibers and other types of waste.



Flygt Concertor 6020 pumps, featuring Adaptive N hydraulics, in a municipal wastewater pump station

## Engineering pumps for today's wastewater composition

Since the early 20th century, pump designers have focused on throughlet size for clog reduction. In mining, industrial and raw water pumping applications, hard, solid and spherical objects in the pumped media were the most common clogging issues, and large impeller throughlets enabled these objects to pass more easily through the pump. While wastewater pumps have also traditionally been designed with large throughlets to avoid clogging, it has proven to be non-optimal for most wastewater applications.

Meanwhile, the risks related to soft and stringy matter – the most common solids found in municipal water – have been largely neglected.

Detailed investigations and studies of modern wastewater have shown that it almost never contains hard and spherical objects with a diameter as large as the inner diameter of the piping system. Even if such objects enter the wastewater system, they are usually deposited or trapped in areas where the carrying velocity is low, and they will not reach the pumps.

Today's wastewater contains a significantly higher proportion of soft objects. The ever-increasing array of household and personal hygiene products, including tissues, wipes, rags, dishcloths and other fibrous objects, is a major problem. While a large proportion of these products should be disposed of in the trash, many consumers flush them down the toilet. Thus, more unbreakable fibers show up in wastewater and further challenge the pumps.

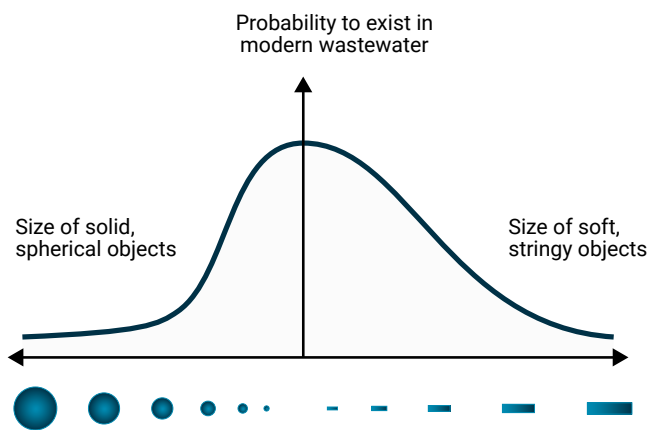

Figure 1: Likelihood of finding various types of solids in wastewater

Figure 1 is a conceptual representation of the probability of finding different types of solids in wastewater. Hard and approximately spherical objects are to the left, while soft and elongated objects are to the right. As in many systems, the probability of finding extremely large objects, either spherical or elongated, is very low. The important characteristic is that this distribution curve is asymmetrical – there is a bias towards soft, elongated objects, which are the most common in today’s wastewater.

## Soft and hard clogging

It has been demonstrated that clogging issues are mainly caused by stringy objects, which tend to get caught on the leading edges of traditional impellers. The fibers wrap around these leading edges and fold over on both sides of the vane. On straight and moderately curved leading edges, the debris will not dislodge; instead, it will continue to build up. These accumulations create large lumps or bundles of solid material (sometimes called “rag balls”) that lead to clogging.

As objects gradually accumulate around the impeller’s leading edges, the free passage of liquid is reduced and pump performance decreases. This phenomenon is called soft clogging because it does not cause the pump to stop. The pump will continue to operate, but performance will be reduced to a certain degree. A typical effect of soft clogging is that the pump will have to operate for a longer time to pump out a given volume of wastewater. The efficiency of a soft-clogged pump is also lower than that of a non-clogged pump. Thus, soft clogging increases energy consumption. A further consequence of soft clogging is higher vibration levels, which leads to accelerated wear of seals and bearings.

Thin foreign objects can also get stuck between the volute and the impeller, causing additional friction. The motor needs to supply even greater torque to counteract the braking effect, so higher input power is required. Once the running current exceeds the trip current (causing motor overload), the pump will stop. This is called hard clogging. Hard clogging can also occur when soft clogging creates significant rag balls. The main effects of hard clogging are downtime and the need for an unplanned service call to unclog and restart the pump, adding to operational expense.

## Debunking the myth of throughlet size

The last few decades of research and development, combined with experience from hundreds of thousands of pump installations, have shown the simplistic logic of throughlet size to be incorrect and misleading. Yet it is still prevalent in wastewater pump procurement specifications. User feedback and laboratory tests with traditional impellers have yielded the results below.

### Clog resistance in channel hydraulics

Channel impellers are single- or multi-vane closed centrifugal impellers with a large throughlet size. They are efficient when pumping clean water but prone to clogging when pumping wastewater.

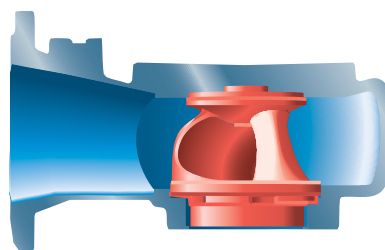

Figure 2: Example of a single-vane impeller

Channel hydraulics are designed to achieve the best clog-resistance at the Best Efficiency Point (BEP) of the pump. Therefore, the further the duty point is from the BEP, the lower the clog-resistance will be. Gradual build-up of fibrous material over the leading edge (Figure 3) will cause pump efficiency to drop well below the factory-tested clean-water value – a typical effect of soft clogging.

This long-used design also suffers from significant radial forces, which cause heavy stress on the shaft and bearings, increasing vibration and noise. Since the impeller is never perfectly balanced, vibration is further increased.

These issues ultimately result in increased energy consumption, excessive wear and a shortened pump lifespan.

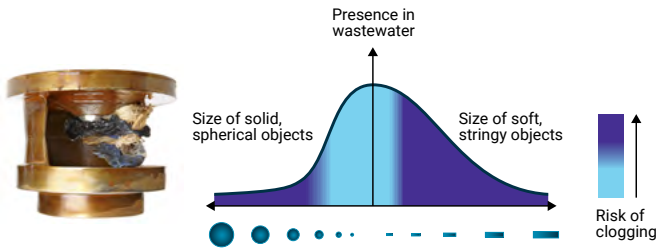

Figure 3: Clogging in channel impellers

soft clogging at the hub and the leading edge. The flow pattern and pressure distribution cause the soft materials to cover the impeller vanes, significantly reducing the already low hydraulic efficiency.

Additionally, vortex pumps tend to accumulate a lot of solids in the volute, causing additional losses, increasing power consumption, and eventually resulting in motor overload and pump shut-off.

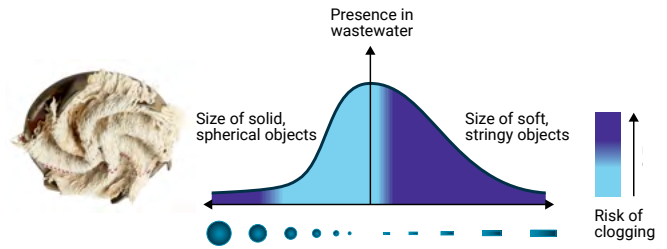

Figure 5: Clogging in vortex impellers

**Clog resistance in vortex hydraulics**

Vortex impellers are recessed from the pump housing, providing a spacious volute but low efficiency with both clean water and sewage.

Pump designers assumed:

- The rotating impeller would create a strong vortex inside the volute that would pump out the liquid and any debris.
- Vortex impellers would work like a torque converter, where energy is transmitted from impeller to pumped media with no or little flow exchange.
- Since the impeller is positioned out of the liquid flow path, objects would never be in contact with the impeller and the pump would not clog.

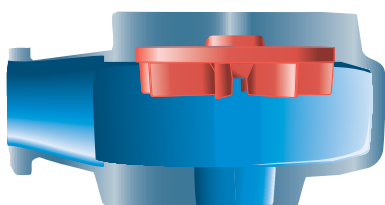

Figure 4: Example of a vortex impeller

However, the vortex impeller functions like any other centrifugal impeller, which means energy is transmitted to the media throughout the impeller vanes. The multi-vane vortex impeller is thus very sensitive to

**Clog resistance in modern self-cleaning hydraulics**

Studies and investigations have shown that clogging issues are mainly related to the difficulty pumps have expelling stringy objects caught around the leading edges of the impeller. The N-impeller, featuring a modern self-cleaning design, was developed in response to these findings. With substantially backswept horizontal leading edges and a relief groove, the N-hydraulic design has proven to be the solution to most clogging problems. Furthermore, without the need for a large throughlet, impellers can be designed with multiple vanes, which helps to reduce radial forces, improve balance and increase efficiency.

Figure 6 shows the clogging probability of the N-impeller, which is much lower than that of a traditional impeller designed around having a large throughlet size.

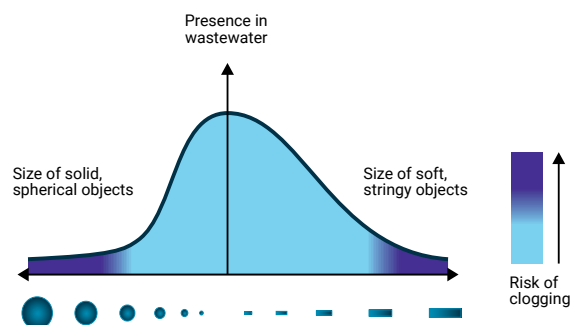

Figure 6: Clogging in self-cleaning N-impellers

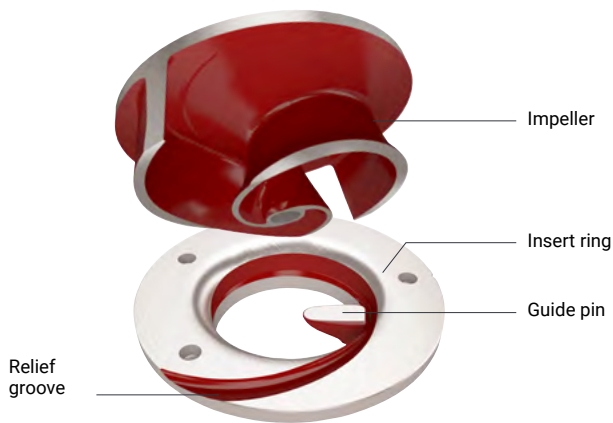

Figure 7: Self-cleaning N-technology hydraulic design

Figure 7 shows the N-hydraulic design, which includes a semi-open N-impeller and an insert ring with a guide pin.

This self-cleaning technology works as follows:

1. The N-impeller blades with backswept horizontal leading edges enable self-cleaning by sweeping solids from the center to the perimeter of the insert ring.
2. The relief groove located in the insert ring acts together with the horizontal leading edge to guide solids out of the impeller.
3. At small-scale geometries, a specially designed guide pin catches any fibers stuck close to the impeller hub and allows the blades to push them out of the pump along the relief groove. The risk of blockage at the hub of semi-open impellers thus becomes negligible.

Thanks to the ability to expel tough objects, the self-cleaning technology considerably reduces unplanned maintenance and increases reliability. By preventing stringy objects from wrapping around the leading edges and causing soft clogging, the N-impeller ensures sustained high efficiency over time and thus lower energy consumption.

Unlike channel hydraulics, the clogging resistance of the self-cleaning N-hydraulics is based on a mechanical principle and is unaffected by flow variations. The pump can therefore run efficiently at different duty points on the performance curve and, above all, at several frequencies with high reliability. Pairing the N-hydraulics with a variable frequency drive (VFD) can result in better process control, energy savings, smoother operation and reduced maintenance costs.

## Self-cleaning N-hydraulics development

### Limited torque of small pumps

A submersible pump is typically driven by an electric motor that is close-coupled with the pump impeller, as shown in Figure 8. When a pump starts, electrical current passes into the winding of the stator and creates a rotating magnetic field, which results in spinning the rotor via the shaft. Consequently, the motor generates torque that is proportional to the motor power. Torque is a physical quantity that defines the tendency of a force to rotate an object around an axis or a point.

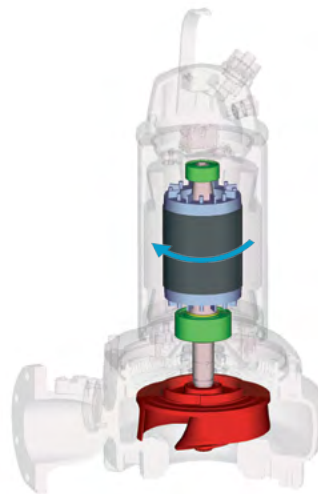

Figure 8: Representation of torque

As discussed earlier, objects passing through a self-cleaning N-pump are pushed out along the relief groove. Since the clearance between the impeller blades and insert ring is very small, just tenths of millimeters, large debris is forced to pass through the relief groove. When this happens, extra friction is created that acts as a brake on the impeller and tends to decelerate it. The pump must provide extra torque to overcome this extra friction, which means higher motor torque is required. If the maximum motor torque is insufficient, the debris will get stuck and stop the pump. This is hard clogging.

As motors for submersible wastewater pumps are usually not greatly oversized, the maximum torque supplied at full power might not be sufficient to push the toughest debris away. This is particularly true for smaller pumps, for which the torque margin becomes comparatively low. To further improve the functionality of small N-pumps, Adaptive N technology was developed to reduce the risk of hard clogging due to insufficient torque.

### Adaptive N technology

With the adaptive technology, the N-impeller is not totally fixed on the shaft: it can move axially up and down in response to a pressure differential created by large debris trying to pass through the pump. The movement temporarily increases the clearance between the impeller blades and the insert ring. This allows the bulkiest rags and the toughest debris to pass smoothly through the pump, without the need for extra motor torque. The benefits are even greater when pump motors are operated on single-phase power sources, where available torque is further reduced.

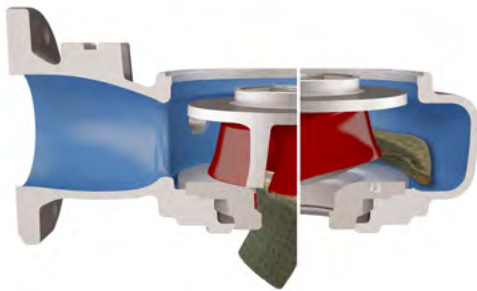

Figure 9: Adaptive N impeller positions during operation

As shown on the left side of Figure 9, most of the time the Adaptive N impeller works in the exact same way as a regular N-impeller. But when needed, the impeller moves up to pass larger debris, as shown on the right side of Figure 9.

The adaptive mechanism works with hydraulic pressure differences over the impeller. The force related to the pressure is  $F=P \times A$ , where P is pressure and A is the area where the pressure is applied. Figure 10 shows how the combined forces determine the impeller position.

On the left side of Figure 10 is a conceptual image of the hydraulic forces distributed on the impeller in lightly contaminated wastewater. At the bottom of the impeller, the upward pressure increases over the radius so the force grows from the center to the edge of the impeller. Meanwhile, at the top of the impeller, a higher pressure acts uniformly on the entire impeller disc. The combined force on the impeller has a net downward value and retains the impeller in the normal operating position.

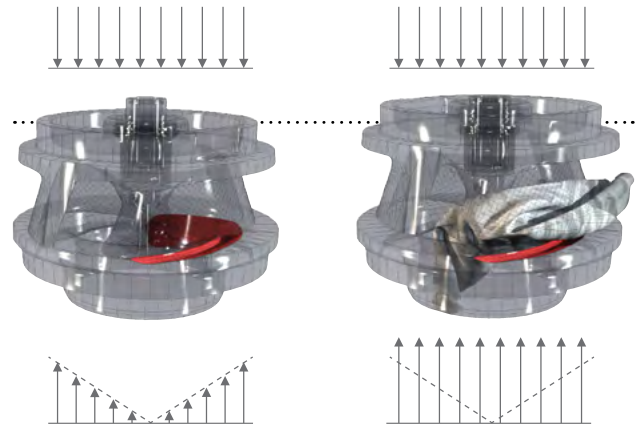

Figure 10: Force distribution during normal operation (left) and when large debris enters the pump (right)

When a large piece of debris enters the impeller, the force balance will differ from normal operation. As shown on the right side of Figure 10, a gradually increasing upward force is added to the hydraulic forces at the impeller bottom. When the upward force exceeds the downward force, the impeller starts moving up and the clearance between the impeller and insert ring becomes larger. When the clearance is large enough, the debris will pass through the impeller. Then the upward force decreases and the impeller returns to its original operating position.

Since this adaptive motion lasts only a fraction of a second, the momentary power increase has no significant effect on overall pump efficiency. This adaptive function also reduces loads on the shaft, seals and bearings and thus increases their lifespan.

In sum, with Adaptive N technology, the self-cleaning functionality for small pumps with low-torque motors is significantly improved. Ultimately, reliable operation and sustained high efficiency lower the total cost of ownership.

Note: Although there is a spring in the impeller hub, it is not connected to the adaptive functionality. The spring keeps the impeller locked during assembly and transport, avoiding potential damage before setup.

## Life cycle cost analysis for small wastewater pumps

Life cycle cost (LCC) analysis is a methodology used to determine the total cost of a system over its lifetime, or to compare investment plans. A complete LCC analysis of any piece of equipment includes all costs related to that equipment, including initial investment, installation, operation, energy, downtime, environmental, maintenance and disposal. The parts of the equation that matter the most will depend on application, geographic location, labor costs and energy cost – factors that can vary significantly between markets.

When evaluating wastewater pump options, a simplified analysis is often used. In this case, the most relevant factors are initial investment, energy cost and maintenance cost (especially unplanned maintenance). Other factors can be excluded from the analysis.

Clogging is the most significant factor in unplanned maintenance costs. The number of times a pump clogs in a pump station can vary greatly. The most common factors are:

- Type of pumped media
- Type of pump hydraulics
- Length of pump operating cycles
- Size of pump
- Motor torque and moment of inertia
- Performance of routine maintenance

### Increased energy cost due to soft clogging

As stated above, a channel-impeller pump in a wastewater application might suffer from soft clogging and may trip after a long operation cycle. A vortex-impeller pump suffering from soft clogging, however, might continue running due to the large space in the pump housing. This larger space allows for more solids accumulation than other types of impellers. In either case, soft clogging tends to reduce pump efficiency and induce hard clogging.

Figure 11 shows the impact of soft clogging on efficiency and energy consumption for traditional pumps (channel or vortex hydraulics) and self-cleaning pumps (N- or Adaptive N hydraulics) over time. As

shown in Figure 11a, when a traditional pump runs continuously in wastewater, efficiency decreases and energy consumption gradually increases. The trend is the same when a traditional pump runs intermittently (Figure 11b), even if back-flushing achieves temporary efficiency gains. In contrast, Figure 11c shows that a self-cleaning pump maintains consistent efficiency and energy consumption during continuous or intermittent operation in wastewater, giving it the lowest energy consumption over time.

Increased energy costs due to soft clogging can easily be measured on site. Predicting these extra costs, however, is difficult due to the variability of media properties and operation cycles.

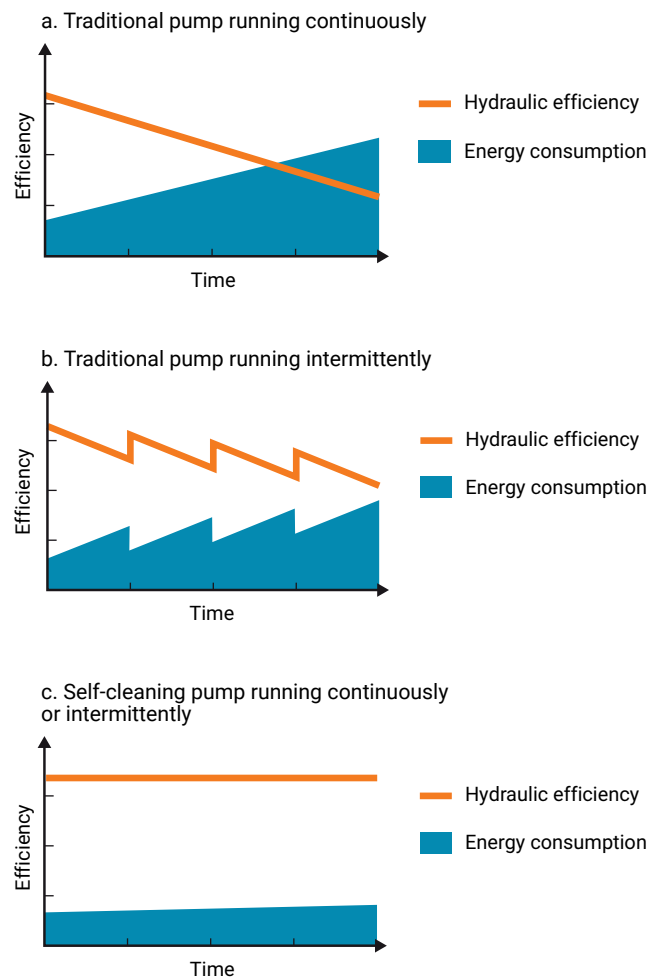

Figure 11: Traditional pump performance under two different operating scenarios compared with a self-cleaning N-technology wastewater pump

### Simplified LCC comparison example

The example below provides a simplified LCC analysis comparing three pump types with short versus extended daily operating hours.

#### Application and pump details

Pump media	Unscreened raw sewage		
Flow	25 l/s		
Head	8 m		
Running years	5 years		
Energy cost*	0.1 € / kWh		
Unplanned maintenance cost	200 € / call-out		
Pump selection	Channel impeller	Vortex impeller	Adaptive N impeller
Rated power (kW)	3.1	4.7	3.1
Hydraulic efficiency (clean water)**	75%	46%	77%
Total efficiency (clean water)**	63%	38%	65%
Specific energy (kWh/m <sup>3</sup> )**	0.0346	0.0574	0.0335
Number of call-outs / year	Operating 3 hours / day	4	2
	Operating 12 hours / day	16	8

\*Energy cost may vary significantly depending on country.

\*\*Efficiency and specific energy figures based on Flygt pump performance curves.

In this example, the initial investment for the various hydraulic types does not make a big difference. In a long operation cycle, the initial investment is only a small proportion of the LCC. In addition, the planned maintenance cost will be approximately the same across the pump options. Meanwhile, the cost of unplanned maintenance due to hard clogging will have a greater impact on LCC.

When the channel-impeller pump runs 12 hours per day over 5 years (Figure 14), the unplanned maintenance cost is more than 5 times the initial investment. Comparatively, the maintenance cost of the Adaptive N impeller pump is only 60% of its initial investment.

While the vortex-impeller pump is expected to have fewer call-outs than the channel-impeller pump, its lower efficiency than the other hydraulic types will result in higher energy costs. This does not even account for the extra energy cost caused by soft clogging, which is difficult to predict and thus not counted in an LCC calculation or in these graphs. Considering this, a vortex-hydraulic pump will have higher energy consumption compared to the other two hydraulics.

Whether operating 3 or 12 hours per day (Figures 13 and 14), the Adaptive N impeller pump has the lowest life cycle cost in wastewater, as it will minimize unplanned maintenance. If the extra energy consumption due to soft clogging is taken into account, the Adaptive N pump can save even more than the LCC analysis indicates. In addition to the economic gains, the N-pump offers trouble-free operation to end users.

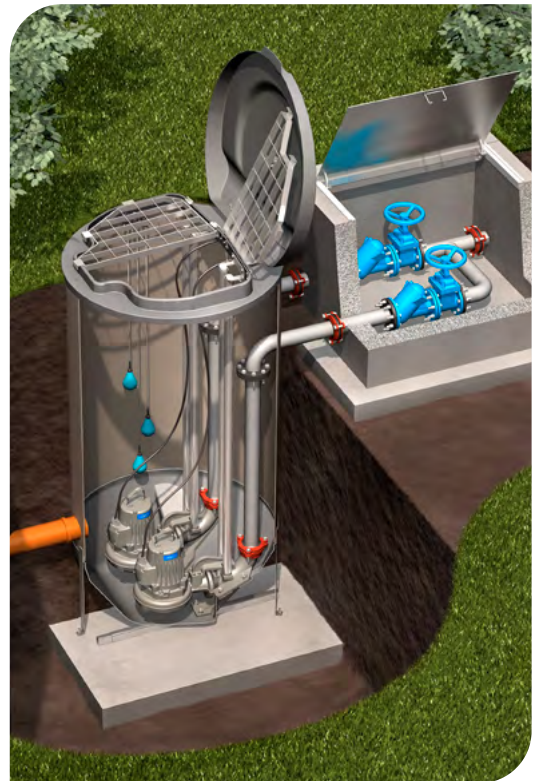

Figure 12: Example of a wet well pump station with two small wastewater pumps

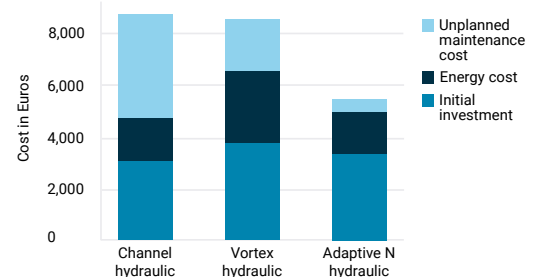

Figure 13: Simplified LCC analysis based on operation 3 hours per day over 5 years

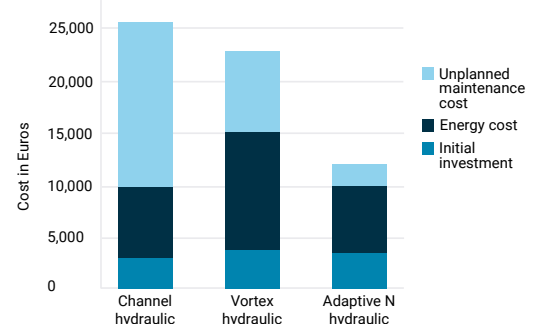

Figure 14: Simplified LCC analysis based on operation 12 hours per day over 5 years

## Summary

The ever-increasing focus on minimizing operating costs creates a demand for pumps with better clog-resistance and higher efficiency, especially in wastewater applications. More than 25 years ago, a self-cleaning hydraulic design was developed for this purpose. Equipped with backswept horizontal leading edges and a relief groove, the semi-open N-impeller can considerably reduce the risk of clogging. Consequently, N-pumps provide sustained high efficiency and higher reliability than traditional hydraulic designs. Self-cleaning N-pumps have therefore been well-received all over the world.

Due to the limited size and motor torque in small wastewater pumps, the use of N-technology has been challenged in the toughest applications. To further enhance the self-cleaning function, especially to reduce the risk of hard clogging in pumps with relatively low torque, the N-impeller has been complemented with adaptive technology. Adaptive N hydraulics allow the impeller to move axially, so the toughest debris can pass through. The results from numerous lab and field tests show that Adaptive N hydraulics can effectively solve both soft and hard clogging issues for small pumps.

Additionally, LCC analysis shows huge potential savings for Adaptive N pumps. In most cases, the savings are derived from lower energy consumption and a reduction in unplanned maintenance costs.